

ON THE VARIATION OF A SERIES ON TEICHMUELLER SPACE

GREG MCSHANE

ABSTRACT. We prove that a certain series defines a constant function using the Kerckhoff-Wolpert formula for the variation of the length of a geodesic along a Fenchel Nielsen twist.

1. INTRODUCTION: TWO QUESTIONS

In [12] we showed that

$$\sum \frac{2}{1 + \exp(l_\gamma)} = 1$$

where l_γ is the length of the closed geodesic freely homotopic to γ and the sum extends over all simple closed curves γ on a hyperbolic once punctured torus. The proof we gave is based on the geometry of (simple) geodesics on a complete hyperbolic surface with at least one puncture. Here we shall present a proof of an analogous identity which emphasises the rôle of the different elements of the modular group and the infinitesimal geometry of the Teichmueller space which appears via a variational formula due to Steve Kerckhoff and Scott Wolpert [10],[26]. As it is not much more difficult we work with surfaces with geodesic boundary as in [14].

Let us begin with two questions of Troels Jorgensen.

Question 1: Jorgensen asked if the above identity could be proved using the *Markoff cubic*

$$a^2 + b^2 + c^2 - abc = 0, \quad a, b, c > 2.$$

In [2] Bowditch answers this giving a proof using a summation argument over the edges of the tree, \mathbf{T} , of solutions to this equation.

Question 2: Jorgensen also asked can the identity be proved using the *Kerckhoff-Wolpert formula* for variation of length? If μ_1, μ_2 are closed simple geodesics on a hyperbolic surface then

$$(1) \quad dl_{\mu_1}.t(\mu_2) = \sum_{z \in \mu_1 \cap \mu_2} \cos(\theta_z),$$

where $t(\mu_2)$ is the Fenchel-Nielsen vector field associated to μ_2 and the sum is over all the intersections between the geodesics. This formula was generalised by Goldman [4],[5] in terms of the natural Poisson bracket on the representation space of a surface group into a semi simple Lie group.

It is this question that we address here. Our starting point is the observation that by clever "accounting" Bowditch avoids considering the following divergent series

$$\sum_{\{a,b,c\} \in \mathbf{T}} \left(\frac{a}{bc} + \frac{b}{ca} + \frac{c}{ab} \right).$$

The series is divergent since \mathbf{T} is infinite and, since a, b, c is a solution of the cubic, the value of each term is 1.

Here we consider another divergent series obtained by summing over the edges of \mathbf{T} . We show that, after a suitable regularization, this yields another series constant on Teichmueller space. The ingredients are:

- A (formal) argument, using an involution of the surface, showing that the series defines a constant function.
- A geometric recipe, using Dehn twists, for finding an explicit expression for the terms in the series.
- A method for finding the value of the series.

This allows us to give a proof of:

Theorem 1. *For a one holed torus M :*

$$\sum_{\gamma} \arctan \left(\frac{\cosh(l_{\delta}/4)}{\sinh(l_{\gamma}/2)} \right) = \frac{3\pi}{2},$$

where the sum extends over all simple closed geodesics γ on M and l_{δ} is the length of the boundary geodesic δ .

1.1. Relation with Mirzakhani's identities. Mirzakhani [14] has obtained identities for hyperbolic surfaces with non-empty geodesic boundary by adapting the methods of [12]. For the one holed torus she obtains

$$l_{\delta} = \sum_{\gamma} 2 \log \left(\frac{e^{\ell_{\delta}/2} + e^{\ell_{\gamma}}}{e^{-\ell_{\delta}/2} + e^{\ell_{\gamma}}} \right),$$

where the sum is over all essential simple curves γ . When one quotients the (holed) torus by the elliptic involution J one obtains an orbifold M/J with a single geodesic boundary component of length $\ell_{\delta}/2$ and three cone singularities of angle π . Philosophically M/J surface is a "hyperbolic four holed sphere with boundary geodesic of lengths $\ell_{\delta}/2, i\pi, i\pi, i\pi$ " where this assertion is to be interpreted as follows. The fundamental group of the four holed sphere is generated by four simple loops $\alpha_1, \alpha_2, \alpha_3, \delta$ which meet only at the base point and each of which is homotopic to a different boundary geodesic. The loops $\alpha_1, \alpha_2, \alpha_3, \delta$ are said to be *peripheral*; after choosing orientations appropriately $\pi_1 = \langle \alpha_1, \alpha_2, \alpha_3, \delta : \delta = \alpha_1 \alpha_2 \alpha_3 \rangle$.

- in the $SL(2, \mathbf{R})$ character variety of π_1 there is a representation ρ such that the quotient is isometric to M/J
- the monodromy around the loop δ is hyperbolic with translation length $\ell_{\delta}/2$.
- the monodromies of the remaining three peripheral curves α, β, γ are elliptic of order 2.

For a hyperbolic four holed sphere with three geodesic boundary components $\alpha_1, \alpha_2, \alpha_3$ such that $\ell_{\alpha_1} = \ell_{\alpha_2} = \ell_{\alpha_3} = L > 0$ Mirzikhani's identities give

$$(2) \quad L = \sum_{\gamma \in A_i} 2 \log \left(\frac{e^{L/2} + e^{(\ell_\gamma + L)/2}}{e^{-L/2} + e^{(\ell_\gamma + L)/2}} \right),$$

where A_i the set of simple curves which bound a pair of pants with δ and α_i . Every non peripheral simple curve belongs to one of the A_i so summing gives

$$(3) \quad 3L = \sum_{\gamma} 2 \log \left(\frac{e^{L/2} + e^{(\ell_\gamma + L)/2}}{e^{-L/2} + e^{(\ell_\gamma + L)/2}} \right),$$

where now the sum is over *all* simple essential γ . Both the right and left hand sides of (3) are restrictions to the $SL(2, \mathbf{R})$ character variety of complex analytic functions defined on a neighborhood $SL(2, \mathbf{C})$ character variety. By analytic continuation one expects this to be true at $L = \pi$. After some algebra and noting that the set of non peripheral simple curves on the four holed sphere and those on the one holed torus are in 1-1 correspondence we obtain the identity in Theorem 1. We note that Ser Tan seems to have known of the existence of a version of (3) for some time and has given a different treatment based on the ideas of Bowditch [19].

1.2. Sketch of proof of Theorem 1. Let \mathcal{P} be the LHS of the identity in the theorem. We show that the variation $d\mathcal{P}$ of the series vanishes identically on the Teichmueller space. To do this we find a series $d\mathcal{Q}$ (see Section 2) which converges absolutely to $d\mathcal{P}$ and a rearrangement showing that the former is identically 0; since Teichmueller space is connected the series \mathcal{P} is constant. Our series $d\mathcal{Q}$ is, at least morally, the derivative of a divergent series \mathcal{Q} which has a nice geometric definition. To define \mathcal{Q} , we introduce the following notation which we shall use throughout the article: Let α, β be a pair of oriented essential simple closed curves meeting in a single point and let $\alpha \vee \beta$ denote the signed angle between the closed simple geodesics in the free homotopy classes determined by α and β (see Section 4 for further discussion). The series \mathcal{Q} is, roughly speaking, the sum over all such $\alpha \vee \beta$.

In dealing with $d\mathcal{Q}$ ($d\mathcal{P}$) we adopt the a point of view similar to that of Kerckhoff [10]; we work with the ‘‘Fenchel-Nielsen geometry’’ of the cotangent bundle (see also Wolpert [24],[25]). We evaluate the pairing of $d\mathcal{Q}$ with the Fenchel-Nielsen vector field $t(\mu)$ associated to a simple closed geodesic μ on $\Sigma_{g,n}$. By a result of Wolpert [23],[24] there are finitely many simple closed geodesics μ_i such that the associated Fenchel-Nielsen vector fields t_{μ_i} generate the tangent space at every point in the Teichmueller space of a surface of finite type. A 1-form vanishes iff its pairing with these fields vanishes. One concludes immediately, since the function $x \mapsto l_\delta(x)$, $\mathcal{T}_{1,1} \rightarrow \mathbf{R}^+$ has connected level sets, that the value of the series depends only on the length of l_δ . It is actually more convenient to think of the torus T as being an (embedded) convex subsurface of a closed surface $\Sigma_{g,n}$. The inclusion $i : T \rightarrow M$ induces a faithful representation of the mapping class group of T in the mapping class group of M . The advantage of this approach is that one can twist along closed geodesics in M that are not contained in $i(T)$ and as such vary the length of the boundary curve l_δ .

The main technical result, on which our proof hinges, can be stated:

Theorem 2. *Let $T \subset \Sigma_{g,n}$ an embedded convex subsurface and let $\mathcal{MCG}^*(T)$ denote the image of the mapping class group of T in the mapping class group of $\Sigma_{g,n}$. Let $\mu \subset \Sigma_{g,n}$ be a simple closed geodesic with $t(\mu)$ the associated Fenchel-Nielsen vector field then the series*

$$d\mathcal{Q}.t(\mu) = \sum_{[g] \in \mathcal{MCG}^*(T)} d([g].(\alpha \vee \beta)).t(\mu)$$

converges absolutely and its sum vanishes.

We use the following corollary of his formula, also due to Wolpert [25], to prove absolute convergence (Section 6) of the

$$|dl_{\mu_1}.t(\mu_2)| \leq \sum_{x \in \mu_1 \cap \mu_2} 1 = \sharp(\mu_1 \cap \mu_2) := i(\mu_1, \mu_2).$$

where $i(\mu_1, \mu_2)$ is the *geometric intersection number*.

1.3. Value of the series. The vanishing of $d\mathcal{P}$ is one of two parts of the proof of the Theorem 1 the other being the determination of the value of the series at some point. This value is shown to be $3\pi/2$ in [13] for any point in the Teichmueller space of the punctured torus, that is when $\ell_\delta = 0$. It is worth note that the usual heuristic of setting $\ell_\gamma = 0$, the result of which is $\pi/2$, gives an incorrect value.

1.4. Comments, Acknowledgements. The original motivation for this work was to extend the formula to spaces of representations of surface groups in Lie groups other than $SL(2, \mathbf{R})$ for which Goldman has established analogues of the the above variational formula in [4]. For example it is not hard to show that our method works in the case of $SL(2, \mathbf{C})$, see Series [22] or Goldman [7] for a discussion of the formula in this case. Though our method should in principle give results in this direction in *certain special cases* (in an appendix we explain why our method appears to break down irretrievably in general) we note that F. Labourie and the author [11] have subsequently established identities using a different method. Bowditch's method has been extended to treat many other cases by Ser Tan [19],[21],[20].

It is a pleasure to thank Troels Jorgensen for the original question and Pete Storm, Benson Farb, Frederic Paulin, Juan Souto for useful conversations and encouragement. Finally, as the referee points out, and we are happy to acknowledge, this article owes much to Scott Wolpert's article [25] which is (still) an excellent introduction to the moduli of the punctured torus.

2. ANOTHER DIVERGENT SERIES

Let M be a *one holed torus*. Let us recall some classical facts about the torus. The fundamental group of M is freely generated by two loops γ_1, γ_2 which meet in a single point and such that their commutator is a loop, δ , around the hole. Denote by $\mathcal{T}_1(\ell_\delta)$ the *Teichmueller space of M* . The mapping class group, \mathcal{MCG} , is defined to be the group of orientation preserving diffeomorphisms fixing the boundary pointwise up to isotopy $\pi_0(\text{Diffeo}^+(M, \partial M))$.

Let M^* be a punctured torus. By the work of Nielsen and Mangel :

$$\pi_0(\text{Diffeo}(M^*)) \cong \text{Aut}(\pi_1)/\text{Inn}(\pi_1) \cong \text{GL}_2(\mathbf{Z}).$$

The mapping class group is index 2 in $\pi_0(\text{Diffeo}(M^*))$ and so isomorphic to $\text{SL}_2(\mathbf{Z})$. There are three (conjugacy classes of) elements of $\text{SL}_2(\mathbf{Z})$ that are of interest to us

$$J = \begin{pmatrix} -1 & 0 \\ 0 & -1 \end{pmatrix}, T = \begin{pmatrix} 1 & 1 \\ 0 & 1 \end{pmatrix}, Q = \begin{pmatrix} 0 & -1 \\ 1 & 0 \end{pmatrix}.$$

Under the Nielsen Mangel isomorphism the elliptic involution goes to J and there is a (primitive) Dehn twist that goes to T . Let \mathcal{MCG}^* denote the mapping class group modulo its center. It is well known that the canonical action of \mathcal{MCG}^* on Teichmueller space is effective [8] and that, for a punctured torus, the center of the mapping class group is generated by the elliptic involution. The center of the mapping class group of the holed torus \mathcal{MCG} is generated by the half Dehn twist round the boundary curve δ and the quotient is isomorphic to \mathcal{MCG}^* .

For an orientation preserving diffeomorphism g we write $[g] \in \mathcal{MCG}^*$ for its mapping class. Let $\alpha \in \pi_1, \alpha \neq 1$ be a closed loop and $[\alpha]$ denote its free homotopy class or equivalently its π_1 conjugacy class. If $g, g' \in [g], [g] \in \mathcal{MCG}^*$ and $\alpha, \alpha' \in \pi_1$ freely homotopic then $g(\alpha), g'(\alpha)$ are freely homotopic i.e. $[g(\alpha)] = [g(\alpha')] = [g'(\alpha')]$; in consequence \mathcal{MCG}^* admits an action on the set of free homotopy classes of closed curves,

$$([g], [\alpha]) \mapsto [g(\alpha)].$$

If M is negatively curved then for each non peripheral loop $\alpha \neq 1$ there is a unique closed geodesic representing its free homotopy class which we shall also denote $[\alpha]$; by identifying a closed geodesic with its free homotopy class we may say that the mapping class group acts on the set of closed geodesics. Note that the set of simple closed loops is invariant under diffeomorphism and so the set of simple closed geodesics, \mathcal{G}_0 , is \mathcal{MCG}^* -invariant.

For $\alpha \neq 1$, ℓ_α denotes the length of the closed geodesic $[\alpha]$ with respect to the metric on M .

Let α, β be a pair of oriented simple closed loops on M meeting in exactly one point. The associated closed geodesics $[\alpha], [\beta]$ are simple and meet in a single point; let $\alpha \vee \beta$ denote the *signed angle* between them (see Section 4 for a precise definition). Now α, β freely generate $\pi_1(M)$ the only automorphism that simultaneously fixes them is the trivial automorphism. Since \mathcal{MCG}^* is a quotient of the group of automorphisms of $\pi_1(M)$, it follows that the stabiliser of $([\alpha], [\beta])$ in \mathcal{MCG}^* is trivial. Moreover, since each $g \in \mathcal{MCG}^*$ is a homeomorphism, the pair of geodesics $[g(\alpha)], [g(\beta)]$ again meet in a single point so

$$[g].(\alpha \vee \beta) := g(\alpha) \vee g(\beta)$$

is well defined and the sign is preserved since g preserves the orientation. After possibly exchanging α, β we may suppose $[g].(\alpha \vee \beta) > 0$ for all $g \in \mathcal{MCG}^*$.

Consider the formal series

$$\mathcal{Q} = \sum_{[g] \in \mathcal{MCG}^*} [g].(\alpha \vee \beta).$$

We determine the “sum” of this series using a coset decomposition and some hyperbolic geometry as follows.

Step one: Let γ be a simple closed curve in a one holed torus and T_γ the Dehn twist along γ . Observe that \mathcal{MCG}^* acts transitively on \mathcal{G}_0 and the stabiliser of $\gamma \in \mathcal{G}_0$ is precisely $\langle T_\gamma \rangle$ so

$$[h] \mapsto [h(\gamma)], \mathcal{MCG}^* / \langle T_\gamma \rangle \rightarrow \mathcal{G}_0$$

is a bijection. We rewrite \mathcal{Q} as a sum over the set of coset representatives $\mathcal{MCG}^*/\langle T_\gamma \rangle$ for γ satisfying (see Section 4):

$$(4) \quad [\beta] = [T_\gamma(\alpha)].$$

We obtain

$$\begin{aligned} \mathcal{Q} &= \sum_{[h] \in \mathcal{MCG}^*/\langle T_\gamma \rangle} \left(\sum_{n \in \mathbf{Z}} [h \circ T_\gamma^n] \cdot (\alpha \vee T_\gamma(\alpha)) \right) \\ &= \sum_{[h] \in \mathcal{MCG}^*/\langle T_\gamma \rangle} \left(\sum_{n \in \mathbf{Z}} [T_{h(\gamma)}^n] \cdot (h(\alpha) \vee T_{h(\gamma)} \circ h(\alpha)) \right) \\ &= \sum_{\gamma' \in \mathcal{G}_0} \left(\sum_{n \in \mathbf{Z}} T_{\gamma'}^n(\alpha') \vee T_{\gamma'}^{n+1}(\alpha') \right). \end{aligned}$$

where the outer sum is over all oriented simple closed geodesics \mathcal{G}_0 and α' is any simple closed geodesic that meets γ' exactly once. Note that the passage from the first to the second line is justified by the following equation

$$h \circ T_\gamma \circ h^{-1} = T_{h(\gamma)}.$$

Step two: we evaluate the inner sum over \mathbf{Z} using the following result, the proof of which is postponed to the end of the next section:

Lemma 2.1. *For each γ' , there exists a (Weierstrass) point $w \in M$, such that for all $i > 0$*

$$[T_{\gamma'}^{i-1}(\alpha')] \cap [T_{\gamma'}^i(\alpha')] = \{w\}.$$

Using the existence of such a w , by induction one obtains the following relation for all $m < n$.

$$\sum_{m < i \leq n} T_{\gamma'}^{i-1}(\alpha') \vee T_{\gamma'}^i(\alpha') = T_{\gamma'}^m(\alpha') \vee T_{\gamma'}^n(\alpha').$$

Moreover, there exist complete simple geodesics $\gamma^{-\infty}, \gamma^{+\infty}$ passing through w and spiraling to γ' such that $T_{\gamma'}^n(\alpha') \rightarrow \gamma^{\pm\infty}$ as $n \rightarrow \pm\infty$, where the convergence is uniform on compact sets of M . In particular,

$$\gamma^{-\infty} \vee \gamma^{+\infty} := \lim_{m, n \rightarrow \infty} T_{\gamma'}^m(\alpha') \vee T_{\gamma'}^n(\alpha').$$

is well defined. The inner sum ‘‘telescopes’’ over n and one obtains:

$$(5) \quad \sum_{n \in \mathbf{Z}} T_{\gamma'}^n(\alpha') \vee T_{\gamma'}^{n+1}(\alpha') = \gamma^{-\infty} \vee \gamma^{+\infty}.$$

A calculation, which we carry out in Section 7, shows that

$$(6) \quad \gamma^{-\infty} \vee \gamma^{+\infty} = \pi - 2 \arctan \left(\frac{\cosh(l_\delta/4)}{\sinh(l_{\gamma'}/2)} \right).$$

Step three: We show that \mathcal{Q} is constant using a different coset decomposition. There is an element of order 2, corresponding to the image of the matrix $Q \in \mathrm{SL}_2(\mathbf{Z})$ in $\mathrm{PSL}_2(\mathbf{Z})$, $q \in \mathcal{MCG}^*$, such that

$$q(\alpha) = \beta, \quad q(\beta) = \alpha^{-1}.$$

Now for any $[g] \in \mathcal{MCG}^*$, $[g(\alpha)]$ and $[g(\alpha)^{-1}]$ determine the same undirected geodesic so that

$$g(\alpha) \vee g(\beta) + g(\beta) \vee g(\alpha^{-1}) = \pi.$$

Rewriting \mathcal{Q} as a sum over cosets of $\mathcal{MCG}^*/\langle q \rangle$, one obtains:

$$(7) \quad \mathcal{Q} = \sum_{g \in \mathcal{MCG}^*/\langle q \rangle} [g].(\alpha \vee \beta) + [g].(\beta \vee \alpha^{-1}) = \sum_{\mathcal{MCG}^*/\langle q \rangle} \pi$$

Although this last identity clearly implies that our series is divergent, it also suggests that the variation of \mathcal{Q} vanishes when viewed as a 1-form on Teichmueller space. Under the hypothesis of absolute convergence, one expects that a suitable “regularization” defines a constant function. In this case the regularization which works is,

$$\mathcal{P} : x \mapsto \sum_{\gamma} 2 \arctan \left(\frac{\cosh(l_{\delta}(x)/4)}{\sinh(l_{\gamma}(x)/2)} \right), \mathcal{T}_1(l_{\delta}) \rightarrow \mathbf{R}.$$

From their expansions as infinite series:

$$d\mathcal{P} = d\mathcal{Q} = \sum_{[g]} d([g].(\alpha \vee \beta)).$$

Absolute convergence (Theorem 2) allows one to pair off terms as in (7) above:

$$d([g](\alpha \vee \beta) + [g].(\beta \vee \alpha^{-1})) .t(\mu) = 0,$$

and so the sum for $d\mathcal{Q}.t(\mu)$ vanishes identically. Since Teichmueller space is connected, \mathcal{P} is constant.

3. MARKOFF TRIPLES, $\mathcal{T}_1(l_{\delta})$

For completeness we present a brief review of the theory of the representation variety of a free group on two generators, define a topological Markoff triple and describe the relationship with the elliptic involution (see Goldman [6] for background).

To each $x \in \mathcal{T}_1(l_{\delta})$ one associates $\rho_x \in \text{Hom}(\pi_1, \text{SL}_2(\mathbf{R}))$, a discrete irreducible representation of π_1 such that the surface M with its metric is isometric to \mathbb{H}^2/ρ_x . Note that, strictly speaking, a point x determines a representation into $\text{PSL}_2(\mathbf{R})$ but, since the surface is uniformized by a discrete torsion free fuchsian group, we may lift into $\text{SL}_2(\mathbf{R})$. The advantage of working in the latter is that the trace provides a natural map. Note that for any $\rho_x \in [\rho_x]$ the length of the geodesic $[\gamma]$ on the surface determined by x satisfies

$$2 \cosh \left(\frac{l_{\gamma}(x)}{2} \right) = |\text{tr } \rho_x(\gamma)|,$$

for any $\gamma \in [\gamma]$; thus traces of matrices and length functions of geodesics are “interchangeable”.

Fix a *topological Markoff triple*, that is a triple of simple loops $\gamma_1, \gamma_2, \gamma_3$ such that

- (1) the pairwise intersections $\{[\gamma_i] \cap [\gamma_j], i \neq j\}$ is triple of distinct points.
- (2) the loops γ_1, γ_2 freely generate $\pi_1(M, \gamma_1 \cap \gamma_2)$.
- (3) $\gamma_3 = \gamma_1^{-1} \gamma_2$.
- (4) the commutator $\delta = \gamma_1 \gamma_2 \gamma_1^{-1} \gamma_2^{-1}$ represents a loop freely homotopic to the boundary curve, which we also denote by δ , of M .

The *trace map* is defined to be

$$\rho \mapsto (\text{tr } \rho(\gamma_1), \text{tr } \rho(\gamma_2), \text{tr } \rho(\gamma_3)) \text{Hom}(\pi_1, \text{SL}_2(\mathbf{R})) \rightarrow \mathbf{R}^3.$$

It is not difficult, by finding explicit matrices for $\rho(\gamma_1), \rho(\gamma_2)$, to show this map is surjective. Observe that $\mathrm{SL}_2(\mathbf{R})$ acts by conjugation on $\mathrm{Hom}(\pi_1, \mathrm{SL}_2(\mathbf{R}))$ and the trace map is clearly constant on the orbit, $[\rho]$, of the representation ρ ; we write $\mathrm{Hom}(\pi_1, \mathrm{SL}_2(\mathbf{R}))/\mathrm{SL}_2(\mathbf{R})$ for the space of orbits. Clearly the trace map induces a map, which we will still call the trace map, on $\mathrm{Hom}(\pi_1, \mathrm{SL}_2(\mathbf{R}))/\mathrm{SL}_2(\mathbf{R})$.

A diffeomorphism h of M acts on $\pi_1(M)$ (on the left) by the automorphism h_* and so h acts on the left on the representation variety by $(h, \rho) \mapsto \rho \circ h_*^{-1}$. If h is isotopic to the identity then $h_*^{-1} = i_\gamma$ for some $\gamma \in \pi_1$, i.e. h_*^{-1} is an inner automorphism, and so $[\rho \circ h_*^{-1}] = [\rho]$, $\forall \rho$. From this we see that $[\rho \circ h_*^{-1}]$ depends only the coset it determines modulo the group of isotopies, that is only on its mapping class $[h]$. Thus one obtains a representation of \mathcal{MCG}^* as a group acting on \mathbf{R}^3 . A more explicit description of the action of \mathcal{MCG}^* on \mathbf{R}^3 can be given by noting that \mathcal{MCG}^* is isomorphic to $\mathrm{PSL}_2(\mathbf{Z})$ and that $\mathrm{PSL}_2(\mathbf{Z})$ splits as the free product $\mathbf{Z}/2\mathbf{Z} * \mathbf{Z}/3\mathbf{Z}$. The generator of $\mathbf{Z}/3\mathbf{Z}$ acts by cyclic permutation on the coordinates x_i whilst, using the trace relations in $\mathrm{SL}_2(\mathbf{R})$, the generator of $\mathbf{Z}/2\mathbf{Z}$ acts by a "flip"

$$(x_1, x_2, x_3) \mapsto (x_2, x_1, x_1x_2 - x_3).$$

A calculation using the generators shows that the so-called Markoff cubic

$$\kappa(x_1, x_2, x_3) = x_1^2 + x_2^2 + x_3^2 - x_1x_2x_3$$

is an invariant function for this action. Geometrically this is a consequence of the fact that every automorphism of the free group preserves the conjugacy class $[\delta] = [\gamma_1\gamma_2\gamma_1^{-1}\gamma_2^{-1}]$ and, by the trace relations, we have

$$(8) \quad \kappa(\mathrm{tr} \rho(\gamma_1), \mathrm{tr} \rho(\gamma_2), \mathrm{tr} \rho(\gamma_3)) = \mathrm{tr} \rho(\delta) + 2 = -2 \cosh(l_\delta/2) + 2.$$

One identifies the component of the level set $\kappa = -2 \cosh(l_\delta/2) + 2$ contained in $X = \{x_1, x_2, x_3 > 2\}$ with the Teichmueller space $\mathcal{T}_1(l_\delta)$ (see [25]). It follows that every function on $\mathcal{T}_1(l_\delta)$ can be expressed as a function of the lengths of the γ_i ; we shall give an explicit expression for $\alpha \vee \beta$ in the next section.

Using the generators above, it is easy to check that the set $X = \{x_1, x_2, x_3 > 2\}$ is invariant under the $\mathrm{PSL}_2(\mathbf{Z})$ -action and, moreover, the action is effective and properly discontinuous on X . The Bass-Serre tree $\mathrm{PSL}_2(\mathbf{Z})$ is isomorphic to the infinite (regular) trivalent tree and so any orbit of the $\mathrm{PSL}_2(\mathbf{Z})$ -action can be given the structure of a tree in the obvious way; this is the generalized (real) Markoff tree. The classical *Markoff tree* has vertices the integer solutions of

$$\kappa(x_1, x_2, x_3) = 0, x_1, x_2, x_3 > 2.$$

(The integer solutions to the Markoff equation above form a single $\mathrm{PSL}_2(\mathbf{Z})$ orbit).

Observations about Markoff triples

- Firstly, given a configuration of loops $\gamma'_i \in [\gamma'_i]$ satisfying the four conditions above, there is an obvious automorphism of π_1 that takes γ_i to γ'_i and, moreover, this automorphism is f_* for some diffeomorphism f . So the Markoff tree enumerates the configurations that appear in the formal series \mathcal{Q} .
- Secondly, for simple loops γ_k , $k = 1, 2, 3$ $\gamma_3 = \gamma_1^{-1}\gamma_2$ iff $T_{\gamma_3}(\gamma_1) = \gamma_2$. and this is none other than the condition (4).

Markoff triples and Weierstrass points

It is well known that M always admits an isometry J corresponding to the central element of \mathcal{MCG}^* and that the quotient M/J is an orbifold – a disk with three cone points one for each of the fixed points of J . Unoriented simple geodesics are invariant for this involution and it is easy to see that the three intersection points of a Markoff triple of geodesics $[\gamma_i] \cap [\gamma_j]$, $i \neq j$ coincide with the fixed points of J . The fixed points of J are *Weierstrass points*.

With this observation, we prove Lemma 2.1.

Proof. Let w be the Weierstrass point not on γ_3 . For each i , $T_{\gamma_3}^i(\gamma_1), T_{\gamma_3}^{i+1}(\gamma_1)$ both intersect $T_{\gamma_3}(\gamma_3) = \gamma_3$ exactly once. So these three curves form a Markoff triple and $T_{\gamma_3}^i(\gamma_1) \cap T_{\gamma_3}^{i+1}(\gamma_1)$ is exactly the Weierstrass point not on γ_3 .

□

4. SIGNED ANGLES

We now define the signed angle between two geodesics at an intersection (compare Kerckhoff [10], Series [22] or Jorgensen [9] for a discussion of signed complex lengths in general.) Subsequently we find an explicit expression in terms of lengths of geodesics and study its behaviour on Teichmueller space.

Definition: Let $\alpha \neq \beta$ be a pair of oriented geodesics in \mathbb{H}^2 meeting in at a point x . There is a well defined *signed angle* between α, β at x ; this is a function from ordered pairs of oriented geodesics to $] - \pi, \pi[$:

$$(\alpha, \beta) \mapsto \alpha \vee_x \beta.$$

One way to define $\alpha \vee \beta$ is to work in the disc model for \mathbb{H}^2 . After conjugating we may assume:

$$\alpha = (-1, 1), \beta = (-e^{i\theta}, e^{i\theta}),$$

for some $\theta \in] - \pi, \pi[$ so that $\alpha \cap \beta = \{0\}$. Now $z \mapsto e^{i\theta}z$ is the unique rotation fixing 0 and taking 1 to $e^{i\theta}$ and hence α (oriented in the direction from -1 to 1) to β (oriented in the direction from $-e^{i\theta}$ to $e^{i\theta}$.) Set $\alpha \vee_x \beta = \theta$.

For a pair of geodesics $[\alpha] \neq [\beta]$ meeting at a point x in a surface M one defines the signed angle at x by lifting to \mathbb{H}^2 . When $[\alpha] \neq [\beta]$ meet at a single point x in the surface we shall omit x and use simply $\alpha \vee \beta$ to denote this angle.

Computation: Let $[\alpha], [\beta]$ be a pair of simple closed geodesics meeting in a single point $x \in M$. For completeness, we show how to calculate the angle $\alpha \vee \beta$ in terms of l_α, l_β and the length of the boundary l_δ (compare [25],[26]). Let $\gamma = \alpha\beta^{-1} \in \pi_1(M, x)$; from the preceding section $[\alpha], [\beta], [\gamma]$ is a Markoff triple of geodesic and the pairwise intersections are the Weierstrass points. The quotient of $[\alpha] \cup [\beta] \cup [\gamma]$ is an embedded geodesic triangle on M/J with vertices at the 3 cone points. The sides of this triangle have lengths $l_\alpha/2, l_\beta/2, l_\gamma/2$, and the (hyperbolic) cosine rule for this triangle is:

$$(9) \quad \cosh(l_\gamma/2) = \cosh(l_\alpha/2) \cosh(l_\beta/2) - \sinh(l_\alpha/2) \sinh(l_\beta/2) \cos(\alpha \vee \beta),$$

so that

$$(10) \quad \alpha \vee \beta = \arccos \left(\frac{\cosh(l_\alpha/2) \cosh(l_\beta/2) - \cosh(l_\gamma/2)}{\sinh(l_\alpha/2) \sinh(l_\beta/2)} \right).$$

One sees immediately that $\alpha \vee \beta$ is continuous on Teichmueller space.

Finally we derive another expression for $\alpha \vee \beta$ which will be useful in the proof of Theorem 2. Replacing in the Markoff cubic using (9) one obtains:

$$(11) \quad \sinh^2(l_\alpha/2) \sinh^2(l_\beta/2) \sin^2(\alpha \vee \beta) = \cosh^2(l_\delta/4),$$

where δ is the boundary geodesic. If, $\alpha \vee \beta \in]0, \pi/2[$ then ,

$$(12) \quad \alpha \vee \beta = \arcsin \left(\frac{\cosh(l_\delta/4)}{\sinh(l_\alpha/2) \sinh(l_\beta/2)} \right).$$

Remark: Another way of thinking of the relation (11) is as a hyperbolic version of the usual formula for the area of a euclidean torus:

$$2l_\alpha l_\beta \sin(\alpha \vee \beta) = \text{area of torus},$$

where α, β are closed Euclidean geodesics meeting in a single point at angle $\alpha \vee \beta$.

The reader is left to check that, unfortunately, the analogous series for the variation of the Euclidean angles does not converge absolutely and so we obtain no new identity on the moduli space of Euclidean structures.

Differentiability: We now study the regularity of $\alpha \vee \beta$ as we vary the surface over Teichmueller space. It is well known [1] that for any closed geodesic γ the function:

$$x \mapsto l_\gamma(x), \mathcal{T}_1(l_\delta) \rightarrow \mathbf{R}^+$$

is differentiable and even real analytic. It is not difficult to see from (10) that $\alpha \vee \beta$ is also real analytic.

From the expression (12) for the angle obtained above:

$$d(\alpha \vee \beta) = \cosh(l_\delta/4) \frac{\coth(l_\alpha/2) dl_\alpha + \coth(l_\beta/2) dl_\beta}{4(\sinh^2(l_\alpha/2) \sinh^2(l_\beta/2) - \cosh^2(l_\delta/4))^{1/2}},$$

provided $|\alpha \vee \beta| \neq \pi/2$ (by equation (11)), i.e. on the complement of the subset where $|\alpha \vee \beta|$ attains its maximum. On this critical set the numerator $\coth(l_\alpha/2) dl_\alpha + \coth(l_\beta/2) dl_\beta$ vanishes and (it is left to the reader to check that) the right hand side defines a form which extends by continuity to the whole of Teichmueller space.

5. THE LENGTH SPECTRUM OF SIMPLE GEODESICS

We prove two lemmata used in the proof of Theorem 2 in the next section. For a discussion of length spectra in general see Schmutz [18].

Notation: Sections 4 and 5 deal with lengths of geodesics and the mapping class group will not figure explicitly. To make this clear we set

$$B^+ := \mathcal{MCG}^*(\alpha, \beta).$$

Let $M_{g,n}$ be a hyperbolic surface of genus g with n punctures and x the corresponding point in the moduli space. Let \mathcal{G}_0 be the set of all simple closed geodesics. Define the *simple length spectrum*, denoted $\sigma_0(x) \subset \mathbf{R}^+$, to be the set $\{l_\gamma, \gamma \in \mathcal{G}_0\}$ counted *with* multiplicities. It is more useful to think in terms of the associated *counting function*:

$$N(\mathcal{G}_0, t) := \#\{\gamma \in \mathcal{G}_0, l_\gamma(x) < t\}.$$

There are two important features of the simple length spectrum:

- (1) The infimum over all lengths $l_\gamma(x)$ of all geodesics is strictly positive and attained for a simple closed geodesic *the systole*, $\text{sys}(x)$. We shall also denote by $\text{sys}(x)$ the length of this geodesic.
- (2) $\sigma_0(M)$ is *discrete* that is $N(\mathcal{G}_0, t)$ is finite for all $t \geq 0$ and moreover has *polynomial growth* [17],[16] that is

$$N(\mathcal{G}_0, t) \leq At^{6g-6+2n},$$

for some $A = A(x) > 0$.

Lemma 5.1. *Let $x \in \mathcal{M}_1(l_\delta)$ then for all $t > 0$ there exists $N = N(t, x) > 0$ such that the inequality:*

$$\sinh(l_\alpha(x)/2) \sinh(l_\beta(x)/2) \geq t,$$

for all but N pairs $(\alpha, \beta) \in B^+$.

Proof:

$$\begin{aligned} \sinh(l_\alpha/2) \sinh(l_\beta/2) &\geq 1/2(\sinh(l_\alpha/2) \sinh(\text{sys}(x)/2) + \sinh(\text{sys}(x)/2) \sinh(l_\beta/2)) \\ &\geq 1/2(l_\alpha + l_\beta) \sinh(\text{sys}(x)/2), \end{aligned}$$

and the lemma follows by the discreteness of the length spectrum. \square

The Collar Lemma: Useful information about the length spectrum can be obtained from the *Collar Lemma* see Buser [3] chapter 4. Given a closed simple geodesic μ there is an embedded collar (= regular tubular neighbourhood of μ) such that

$$(\text{width of collar round } \mu) \geq w(l_\mu),$$

for $w(s) := 2\text{arcsinh}(1/\sinh(s/2))$. One bounds from below the length of any closed geodesic γ such that $\gamma \cap \mu \neq \emptyset$ by the intersection number times the width the collar round μ , that is

$$(13) \quad i(\gamma, \mu) \leq \frac{l_\gamma}{w(l_\mu)},$$

where $i(\gamma, \mu) := \#\gamma \cap \mu$ is the *geometric intersection number*.

6. BOUNDING THE VARIATION OF \mathcal{Q} : PROOF OF THEOREM 2

Proof of theorem 2: Fix a metric on M , let $x \in \mathcal{M}_1(l_\delta)$ be the corresponding point in the moduli space, and fix μ a closed simple geodesic.

Claim: there exists $K = K(\text{sys}(x), l_\mu, l_\delta)$ such that

$$\sum_{B^+} |d(\alpha \vee \beta).t(\mu)| \leq K \left(\sum_{\gamma \in \mathcal{G}_0} l_\gamma e^{-\frac{l_\gamma}{2}} \right)^2.$$

Convergence follows since the simple length spectrum grows polynomially.

To prove the claim above we start with the formula obtained for $\alpha \vee \beta$ in Section 3:

$$d(\alpha \vee \beta) = \cosh(r) \frac{\coth(a)da + \coth(b)db}{(\sinh^2(a) \sinh^2(b) - \cosh(r))^{1/2}}$$

where to simplify notation:

$$a = l_\alpha/2, \quad b = l_\beta/2, \quad r = l_\delta/4.$$

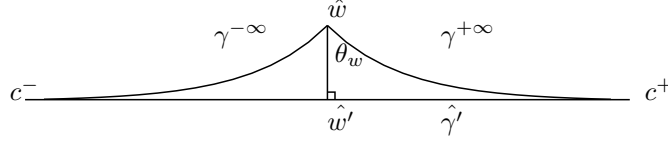

FIGURE 1. The triangle in \mathbb{H}^2 used to calculate $\gamma^{-\infty} \vee \gamma^{+\infty}$.

For the geodesic μ Wolpert's corollary gives:

$$|d(\alpha \vee \beta).t(\mu)| \leq \left| \frac{\cosh(r)(\coth(a)i(\alpha, \mu) + \coth(b)i(\beta, \mu))}{\sinh(a)\sinh(b)(\sinh^2(a)\sinh^2(b) - \cosh^2(r))^{1/2}} \right|.$$

Firstly, note that $\coth(a), \coth(b) \leq \coth(\text{sys}(x)/2)$ since $a, b \geq \text{sys}(x)/2$. Secondly, replacing for $i(\alpha, \mu), i(\beta, \mu)$ using (13) above we obtain the following majoration for the variation:

$$\left(\frac{\cosh(r)\coth(\text{sys}(x)/2)}{w(l_\mu)} \right) \times \left(\frac{l_\alpha + l_\beta}{(\sinh^2(a)\sinh^2(b) - \cosh^2(r))^{1/2}} \right),$$

Note that the leading factor does not depend on l_α, l_β .

Thirdly, by Lemma 5.1 for all but finitely many pairs (α, β) in B^+ one has:

$$\sinh^2(a)\sinh^2(b) - \cosh^2(r) \geq \frac{1}{2}\sinh^2(a)\sinh^2(b) \geq \frac{1}{8}\exp(a+b).$$

Finally, the sum over all the configurations satisfies

$$\sum_{B^+} (l_\alpha + l_\beta)e^{-\frac{1}{2}(l_\alpha + l_\beta)} \leq \frac{2}{\text{sys}(x)} \left(\sum_{\alpha} l_\alpha e^{-\frac{1}{2}l_\alpha} \right)^2,$$

since

$$\frac{2}{\text{sys}(x)} l_\alpha l_\beta \geq l_\alpha + l_\beta.$$

The claim follows immediately. □

7. CALCULATION OF THE TERM IN THEOREM 1

As promised in Section 2 we now derive the formula (6). We pick up at the end of *step two* Section 2 and adopt the same notation. In particular, we have a geodesic γ' , a Weierstrass point w not on γ' and a pair of simple geodesics γ^\pm spiralling to γ' . We lift to \mathbb{H}^2 and use hyperbolic trigonometry to do the calculation (Figure 1).

Let $\hat{\gamma}'$ be a lift of γ' to \mathbb{H}^2 with endpoints c^-, c^+ in $\partial\mathbb{H}^2$. For a point $\hat{w} \in \mathbb{H}^2$, let $\hat{w}' \in \hat{\gamma}'$ denote the nearest point to \hat{w} on $\hat{\gamma}'$; we write $|\hat{w}'\hat{w}|$ for the hyperbolic distance from \hat{w} to \hat{w}' . The triangle $\hat{w}'\hat{w}c^+$ is a hyperbolic triangle with a right angle at \hat{w}' . and an angle $\theta_{\hat{w}}$ at \hat{w} . Trigonometry yields (see Buser [3] Theorem 2.2.2 (iv))

$$(14) \quad \cot(\theta_{\hat{w}}) = \sinh(|\hat{w}'\hat{w}|).$$

Note that the side opposite \hat{w} has infinite length but the passage to the limit in the formula (iv) is valid.

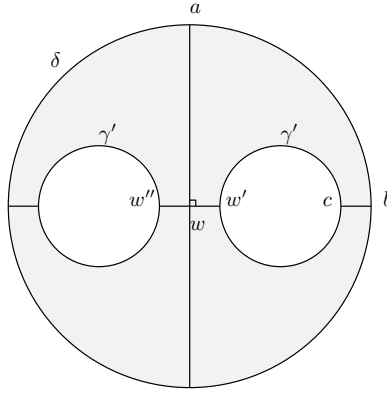

FIGURE 2. The figure shows a torus cut along a geodesic γ' to obtain a pair of pants. The pants has been subdivided into four congruent pentagons.

We now choose \hat{w} to be a lift of the Weierstrass point w such that $\hat{w}'\hat{w}$ projects to a simple arc on the surface. The geodesic $\hat{w}c^+$ projects to a simple geodesic on the surface that spirals to γ' and, without loss of generality, we may assume that this is $\gamma^{+\infty}$. Likewise the projection of $\hat{w}c^-$ is simple and spirals to γ' so this must be $\gamma^{-\infty}$. It follows from this that

$$|\gamma^{-\infty} \vee \gamma^{+\infty}| = 2\theta_{\hat{w}}.$$

It only remains to express the quantity $|\hat{w}'\hat{w}|$ in terms of the lengths ℓ_δ, ℓ_γ . Note first that this quantity is the distance from w to γ' . Now cut along γ' to obtain a pantalon P . The Weierstrass point w is now the midpoint of the unique simple common perpendicular, labelled $w'w''$ in Figure 2, running between the two boundary components of the pantalon corresponding to γ' . By further cutting along common perpendiculars (see Figure 2) one obtains four congruent right angled pentagons; we shall work with the pentagon whose vertices are labelled $abcw'w$. There are three sides of this pentagon that concern us. The side labelled ww' has length $|\hat{w}'\hat{w}|$, the side adjacent, labelled $w'c$, has length $\ell_\gamma/2$ and the side “opposite” this pair, labelled ab , has length $\ell_\delta/4$. The lengths of these three sides are related by (see Buser [3])

$$(15) \quad \sinh(|\hat{w}'\hat{w}'|) \sinh(\ell_\gamma/2) = \cosh(\ell_\delta/4)$$

so that, replacing in (14), one has

$$\cot\left(\frac{1}{2}|\gamma^{-\infty} \vee \gamma^{+\infty}|\right) = \cot(\theta_{\hat{w}}) = \frac{\cosh(\ell_\delta/4)}{\sinh(\ell_\gamma/2)}.$$

This is equivalent to (6).

It is amusing, as an afterthought, to note that the relation (15) can be deduced from (11) in Section 4. One reglues the pantalon P to obtain a holed torus such that the endpoints of the common perpendicular w', w'' are identified. In this way one obtains a holed torus with a simple closed geodesic α' which meets γ'

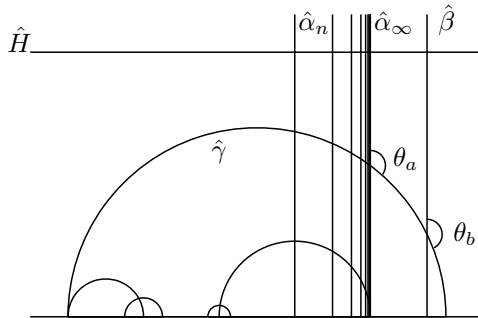

FIGURE 3. The figure shows a choice of lifts of $\alpha_\infty, \beta, \gamma$ to \mathbb{H}^2 as well as the angles θ_a, θ_b .

perpendicularly in a single point. The formula (11) applies with $\alpha = \alpha', \beta = \gamma'$ and, noting that $\gamma' \vee \alpha' = \pi/2$, yields (15).

8. APPENDIX

The curious reader might wonder why we do not give a proof of the original identity using this method. We explain in this appendix how our method breaks down in general.

One can consider an analogous series which is roughly speaking the sum of all of Penner's h -lengths. Recall that the h -lengths are the lengths of the connected components (horocyclic arcs) obtained when one removes the intersection with the edges of an ideal triangulation from the horocycles, see [15] for a details. In the case of the punctured torus there are three h -lengths satisfying a single relation and these can be identified with the quantities $a/bc, b/ac, c/ab$ arising in the discussion of Bowditch's method in the introduction.

Every punctured torus contains a cusp region X of area 2, the boundary is an embedded topological circle H . We choose once and for all an orientation for this circle. Let α be a simple directed bicuspidal geodesic; it meets H in exactly two points a^-, a^+ joining a^- to a^+ . If α, β are a pair of disjoint simple directed bicuspidal geodesics then define the directed h -coordinate $\alpha \vee_h \beta$ to be the distance along the oriented curve H from a^- to b^- . Using the elliptic involution one sees that replacing a^- by a^+ and b^- by b^+ one gets the same number.

For any pair of disjoint simple directed bicuspidal geodesics one also has the identity

$$\beta \vee_h \alpha + \alpha \vee_h \beta = 2$$

since the length of H is 2. The mapping class group acts on pairs of disjoint simple directed bicuspidal geodesics and there are exactly two orbits. For any pair of disjoint simple directed bicuspidal geodesics α, β there is exactly one closed simple geodesic that meets each of α, β exactly once. After choosing orientations appropriately we may assume β is the image of α under the Dehn twist T_γ . One checks that the sum

$$\sum_{n \in \mathbf{Z}} T_\gamma^n(\alpha) \vee T_\gamma^{n+1}(\alpha)$$

converges to $1 - 1/(1 + e^{\ell_\gamma})$.

What goes wrong is the following.

Let β' denote the unique closed simple geodesic disjoint from β and $T_{\beta'}$ the corresponding Dehn twist. The geodesics β' and α meet (exactly once) and consider the associated sequence of directed geodesics $T_{\beta'}^n(\alpha)$, $n > 0$. Let $a_n^- \in H$ denote the corresponding sequence of points realising the value of $T_{\beta'}^n(\alpha) \vee_h \beta$. There is a geodesic α_∞ asymptotic to β with a single endpoint up the cusp such that as $n \rightarrow \infty$ a_n^- tends to the intersection $a_\infty = \alpha_\infty \cap H$. Note that $a_\infty \neq \beta^-$.

Now choose another simple closed geodesic $\gamma \neq \beta$; note that these two geodesics must meet at least once. For large n value of $d(T_{\beta'}^n(\alpha) \vee_h \beta) \cdot \tau_\gamma$ is bounded below by $|\cos(\theta_a) - \cos(\theta_b)|$ where θ_a is the angle between a lift of α_∞ to \mathbb{H}^2 and the first lift of γ that it meets and θ_b the angle between a lift of β and the first lift of γ that it meets (see figure). One sees in this way that the corresponding series for the variation does not converge since terms do not tend to 0.

Note that this reasoning fails in the case considered in the text. This is because if α', β' are simple closed geodesics which meet in a single point then $T_{\beta'}^n(\alpha') \vee \beta' \rightarrow 0$ as $n \rightarrow \infty$ (see [13] for details).

REFERENCES

- [1] A. Abikoff. *The real analytic theory of Teichmüller space, Lecture notes in mathematics, 820*. Springer, New York, 1980.
- [2] B. H. Bowditch. A proof of McShane's identity via Markoff triples. *Bull. London Math. Soc.*, 28(1):73–78, 1996.
- [3] Peter Buser. *Geometry and spectra of compact Riemann surfaces*, volume 106 of *Progress in Mathematics*. Birkhäuser Boston Inc., Boston, MA, 1992.
- [4] William M. Goldman. The symplectic nature of fundamental groups of surfaces. *Adv. in Math.*, 54(2):200–225, 1984.
- [5] William M. Goldman. Invariant functions on Lie groups and Hamiltonian flows of surface group representations. *Invent. Math.*, 85(2):263–302, 1986.
- [6] William M. Goldman. The modular group action on real $SL(2)$ -characters of a one-holed torus. *Geom. Topol.*, 7:443–486 (electronic), 2003.
- [7] William M. Goldman. The complex-symplectic geometry of $SL(2, \mathbb{C})$ -characters over surfaces. In *Algebraic groups and arithmetic*, pages 375–407. Tata Inst. Fund. Res., Mumbai, 2004.
- [8] Nikolai V. Ivanov. *Subgroups of Teichmüller modular groups*, volume 115 of *Translations of Mathematical Monographs*. American Mathematical Society, Providence, RI, 1992. Translated from the Russian by E. J. F. Primrose and revised by the author.
- [9] Troels Jorgensen. Composition and length of hyperbolic motions. In *In the tradition of Ahlfors and Bers (Stony Brook, NY, 1998)*, volume 256 of *Contemp. Math.*, pages 211–220. Amer. Math. Soc., Providence, RI, 2000.
- [10] Steven P. Kerckhoff. The Nielsen realization problem. *Ann. of Math. (2)*, 117(2):235–265, 1983.
- [11] Francois Labourie and Greg McShane. Cross ratios and identities for higher Thurston theory. *arXiv:math.DG/0611245*, 2005.
- [12] Greg McShane. Simple geodesics and a series constant over Teichmüller space. *Invent. Math.*, 132(3):607–632, 1998.
- [13] Greg McShane. Weierstrass points and simple geodesics. *Bull. London Math. Soc.*, 36(2):181–187, 2004.
- [14] Marayam Mirzakhani. Simple geodesics on hyperbolic surfaces and volumes of moduli space. to appear *Invent Math.*
- [15] R. C. Penner. Decorated Teichmüller theory of bordered surfaces. *Comm. Anal. Geom.*, 12(4):793–820, 2004.
- [16] Mary Rees. An alternative approach to the ergodic theory of measured foliations on surfaces. *Ergodic Theory Dynamical Systems*, 1(4):461–488 (1982), 1981.
- [17] Igor Rivin. Simple curves on surfaces. *Geom. Dedicata*, 87(1-3):345–360, 2001.

- [18] Paul Schmutz Schaller. Geometry of Riemann surfaces based on closed geodesics. *Bull. Amer. Math. Soc. (N.S.)*, 35(3):193–214, 1998.
- [19] Ying Zhang Ser Peow Tan, Yan Loi Wong. Generalized markoff maps and McShane’s identity. *math.GT/0502464*, 2004.
- [20] Ying Zhang Ser Peow Tan, Yan Loi Wong. Generalizations of McShane’s identity to hyperbolic cone-surfaces. *J. Differential Geom.*, 72(1):73–112, 2006.
- [21] Ying Zhang Ser Peow Tan, Yan Loi Wong. Necessary and sufficient conditions for McShane’s identity and variations. *Geom. Dedicata*, 119:199–217, 2006.
- [22] Caroline Series. An extension of Wolpert’s derivative formula. *Pacific J. Math.*, 197(1):223–239, 2001.
- [23] Scott Wolpert. The length spectra as moduli for compact Riemann surfaces. *Ann. of Math. (2)*, 109(2):323–351, 1979.
- [24] Scott Wolpert. The Fenchel-Nielsen deformation. *Ann. of Math. (2)*, 115(3):501–528, 1982.
- [25] Scott Wolpert. On the Kähler form of the moduli space of once punctured tori. *Comment. Math. Helv.*, 58(2):246–256, 1983.
- [26] Scott Wolpert. On the symplectic geometry of deformations of a hyperbolic surface. *Ann. of Math. (2)*, 117(2):207–234, 1983.