

ABELIAN INTEGRALS RELATED TO MORSE POLYNOMIALS AND PERTURBATIONS OF PLANE HAMILTONIAN VECTOR FIELDS

by Lubomir GAVRILOV

Contents.

1. Introduction 2. Modules of polynomial differential forms 3. Milnor bundles 4. Abelian integrals related to Morse polynomials 5. Polynomial perturbations of conservative vector fields 6. Abelian integrals which arise in polynomial perturbations of quadratic Hamiltonian vector fields with a center
6.1. Generic quadratic Hamiltonian vector fields with a center
6.2. Reversible quadratic Hamiltonian vector fields with a center 7. Polynomial deformations of a quadratic Hamiltonian vector field and non-oscillation of Abelian integrals Bibliography

1. Introduction.

Let

$$X_H = H_y \frac{\partial}{\partial x} - H_x \frac{\partial}{\partial y}$$

be a polynomial Hamiltonian vector field. Consider a small polynomial deformation

$$X_\varepsilon = X_H + \varepsilon Y + o(\varepsilon)$$

of X_H , where

$$Y = P(x, y) \frac{\partial}{\partial x} + Q(x, y) \frac{\partial}{\partial y}$$

Key words: Abelian integrals – Limit cycles.

Math. classification: 35C05 – 34C10.

is a polynomial vector field of degree n , $\deg P \leq n$, $\deg Q \leq n$. By abuse of notations $o(\varepsilon)$ denotes a vector field, whose norm on any compact domain $K \subset \mathbb{R}^2$ is of type $o(\varepsilon)$. The present paper is a contribution in the study of the number of the limit cycles (isolated periodic orbits) of the perturbed vector field X_ε for sufficiently small $|\varepsilon|$.

Suppose that the vector field X_H has a non-degenerate singular point which is a center. Without loss of generality we assume that it is located at the origin and

$$H(x, y) = \frac{1}{2}(x^2 + y^2) + \dots$$

Consider the continuous family of ovals

$$\gamma(h) \subset \{(x, y) \in \mathbb{R}^2: H(x, y) = h\}$$

which tend to the origin in \mathbb{R}^2 as $h \rightarrow 0$, and are defined on a maximal open interval $(0, \tilde{h})$. Let ℓ be a closed arc, contained in the open period annulus

$$\bigcup_{h \in (0, \tilde{h})} \gamma(h),$$

and transversal to the family of ovals $\gamma(h)$. For sufficiently small $|\varepsilon|$ the arc ℓ is still transversal to the vector field X_ε , and can be parameterized by $h = H(x, y)|_\ell$. Therefore we can define, on a suitable open subset of ℓ , the first return map $h \mapsto P_\varepsilon(h)$ associated to the vector field X_ε and the arc ℓ , as it is shown on Fig. 1. The limit cycles of the perturbed vector field X_ε correspond to the fixed points of the analytic map $P_\varepsilon(h)$.

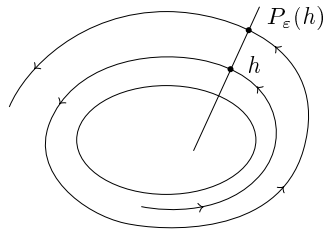

Figure 1. The first return map $P_\varepsilon(h)$ associated to the vector field X_ε and the arc ℓ

As $P_0(h) = h$, then we have

$$P_\varepsilon(h) - h = -\varepsilon I_Y(h) + o(\varepsilon),$$

where the Poincaré-Pontryagin function $I_Y(h)$ [25] is given by

$$(1) \quad I_Y(h) = \iint_{\{H \leq h\}} \operatorname{div}(Y) \, dx \wedge dy, \quad \operatorname{div}(Y) = P_x + Q_y.$$

One may deduce that if k limit cycles of the perturbed vector field X_ε tend to an oval $\{H = h_0\}$, $h_0 \in (0, \tilde{h})$, then the function $I_Y(h)$ has a zero at h_0 of multiplicity at least k (Corollary 4).

In contrast to the first return map $P_\varepsilon(h)$, the Poincaré-Pontryagin function $I_Y(h)$ does not depend on the choice of the arc ℓ . It turns out that if k limit cycles of the vector field X_ε tend to the origin in \mathbb{R}^2 as $\varepsilon \rightarrow 0$, then $I_Y(h)$ has a zero at $h = 0$ of multiplicity at least $k + 1$ (Corollary 5). Suppose finally that the closure of the period annulus

$$\overline{\bigcup_{h \in (0, \tilde{h})} \gamma(h)}$$

is bounded by a homoclinic loop containing one non-degenerate saddle point of the vector field X_ε . Here once again the number of the limit cycles of X_ε which tend to the closed loop, as $\varepsilon \rightarrow 0$, is less or equal to the multiplicity (in a generalized sense) of the zero of $I_Y(h)$ at $h = \tilde{h}$, as it has been proved by Roussarie [26].

The above provides a method to find the number and the location of the limit cycles of X_ε , which tend to the closure of the period annulus of the non-perturbed Hamiltonian system, subject to the following restrictions:

- the Poincaré-Pontryagin function $I_Y(h)$ does not vanish identically;
- the closure of the period annulus of the vector field X_H is bounded by a homoclinic loop with a non-degenerate saddle point.

A concrete application of this will be given in Section 7.

Consider the real vector space \mathcal{A} (of infinite dimension) formed by all Poincaré-Pontryagin functions $I(h) = I_Y(h)$ of the form (1), where $P(x, y)$, $Q(x, y)$ are real polynomials of arbitrary degree. The real functions $I(h)$ are most naturally studied in a complex domain, $h \in \mathbb{C}$. In this case the oval $\{H = h\} \subset \mathbb{R}^2$ represents a cycle $\gamma(h) \in H_1(H^{-1}(h), \mathbb{Z})$ on the complex affine algebraic curve

$$H^{-1}(h) = \{(x, y) \in \mathbb{C}^2: H(x, y) = h\}$$

and $I(h)$ is called an *Abelian integral*. The vector space of Abelian integrals \mathcal{A} is a module over the ring $\mathbb{R}[h]$ of real polynomials in one variable h :

if $I(h) \in \mathcal{A}$, then $hI(h) \in \mathcal{A}$. It was proved in [7] that for a fixed generic polynomial H the $\mathbb{R}[h]$ module \mathcal{A} is free and has μ generators, where μ is the number of the critical points of H . In the present paper we consider the case when H is a Morse polynomial. This means that all its critical points are of Morse type (but it can have multiple critical values). We also suppose that for suitable weights the highest order weight-homogeneous part of H has an isolated critical point at the origin. Under these assumptions we prove that \mathcal{A} is a free $\mathbb{R}[h]$ module of rank $\tilde{\mu} \leq \mu$. The rank $\tilde{\mu}$ of \mathcal{A} is computed in the following way. The cycle $\gamma(h) \in H_1(H^{-1}(h), \mathbb{Z})$ represents a locally constant section of the global homology Milnor bundle E , associated to the global Milnor bundle $\mathbb{C}^2 \xrightarrow{H} \mathbb{C}$ of the polynomial $H(x, y)$. For a fixed regular value h_0 , denote by $E_{\gamma(h_0)} \subset E_{h_0}$ the minimal complex vector space which contains the orbit of the cycle $\gamma(h_0)$ under the action of the monodromy group of H . Then (Corollary 2)

$$\tilde{\mu} = \dim E_{\gamma(h_0)}.$$

The paper is organized as follows. In Section 2 we recall the definition of the Petrov module \mathcal{P}_H associated to a polynomial H and its main properties. In Section 3 we define the global homology Milnor bundle E of a semiweighted homogeneous polynomial, and prove some properties of the subbundle $E_\gamma \subset E$ associated to the locally constant section $\gamma(h) \in E_h$. This is used in Section 4, where we establish our main result (Theorem 2). The rest of the paper is devoted to applications.

Let H be a real cubic polynomial, such that X_H has a center at the origin. The corresponding $\mathbb{R}[h]$ modules \mathcal{P}_H , \mathcal{A} and its generators are computed in Section 6. We compute then the dimension of the real vector space $\mathcal{A}_n \subset \mathcal{A}$, formed by Abelian integrals (1) such that $\deg(P), \deg(Q) \leq n$. Part of these results are already known to the specialists [12], others were used without justification or were erroneously stated (see Remark 5 after Theorem 4 in Section 7). They can be used either as an illustration of Theorem 2, or as a reference in further study of the following Hilbert-Arnold problem.

For a fixed real polynomial $H(x, y)$ denote by $Z(H, n)$ the *exact* upper bound for the number of the zeros of degree n Poincaré-Pontryagin functions (1), $\deg P, \deg Q \leq n$, on a maximal interval on which the oval $\{H = h\}$ exists. The Hilbert-Arnold problem (called “weakened 16th Hilbert problem” in [4], p. 313, and [17]) is

$$\textit{Find the numbers } Z(m, n) = \sup_{\deg H \leq m} \{Z(H, n)\}.$$

According to Varchenko-Khovanskii Theorem $Z(m, n) < \infty$. On the other hand we have obviously

$$Z(H, n) \geq \dim \mathcal{A}_n - 1.$$

It was proved recently [12] that

$$Z(3, n) \leq 5n + 15$$

but the exact value of $Z(3, n)$ is still unknown (even for $n = 2!$). For special Hamiltonians H the numbers $Z(H, n)$ are computed in [22], [23], [24], [8] and [9].

In the last section we compute $Z(H, n)$ and then study the number of the limit cycles of X_ε for a new class of cubic Hamiltonians H . Namely, suppose that X_H is a quadratic vector field with a center, such that

- X_H is reversible (it has an axis of symmetry);
- X_H has exactly one center and one saddle equilibrium point.

In this case the Hamiltonian function can be put (after a \mathbb{R} -linear change of the variables) in the following normal form:

$$H(x, y) = \frac{1}{2}(x^2 + y^2) - \frac{1}{3}x^3 + axy^2, \text{ where } -\frac{1}{2} < a \leq 0.$$

We show first that

$$Z(H, n) = \dim \mathcal{A}_n - 1 = n - 1$$

(Theorem 4), that is to say the real vector space \mathcal{A}_n has the so called Chebishev property [3]. In the case $a = 0$ this result is due to Bogdanov, Il'yashenko ($n = 2, 3$) and Petrov [22], [23] (for arbitrary n). The main difficulty to study the case $-\frac{1}{2} < a < 0$ is that while for $a = 0$ the rank of the module \mathcal{A} is equal to two, in the case $-\frac{1}{2} < a < 0$ it equals to three. To prove our result we count zeros of Abelian integrals in a complex domain by making use of the argument principle. We use the reciprocity law for differential forms of first and third kind. It should be noted that the Chebishev property does not hold true in general even for cubic reversible polynomials [12]. It depends on the monodromy group of the global homology Milnor bundle of the polynomial H (compare for example the Dynkin diagrams shown on Fig. 3).

Suppose at last that, in addition, the Poincaré-Pontryagin function $I_Y(h)$ associated to the perturbed vector field X_ε is not identically zero. We prove that the exact upper bound for the number of the limit cycles of the perturbed vector field X_ε , in any compact domain $K \subset \mathbb{R}^2$ is $n - 1$. For $a = 0$ this was proved by Mardešić [19].

Acknowledgments. — We thank E. Horozov and I. Iliev for the stimulating discussions and critical remarks.

2. Modules of polynomial differential forms.

The results of this section hold over \mathbb{C} or \mathbb{R} . Therefore we denote by \mathbb{K} either the field of complex numbers \mathbb{C} , or the field of real numbers \mathbb{R} . Let $f \in \mathbb{K}[x, y]$ be a polynomial and consider the quotient vector space \mathcal{P}_f of polynomial one-forms

$$\omega = P dx + Q dy,$$

modulo one-forms $dA + Bdf$ where A, B are polynomials. The quotient space \mathcal{P}_f is a module over the ring of polynomials $\mathbb{K}[t]$, under the multiplication

$$R(t) \cdot \omega = R(f)\omega, \quad R \in \mathbb{K}[t].$$

Recall that a function $f: \mathbb{C}^2 \rightarrow \mathbb{C}$ is called weighted homogeneous (wh) of weighted degree d and type

$$\mathbf{w} = (w_x, w_y),$$

$w_x = \text{weight}(x) \in \mathbb{R}$, $w_y = \text{weight}(y) \in \mathbb{R}$ if

$$f(z^{w_x}x, z^{w_y}y) = z^d f(x, y), \quad \forall z \in \mathbb{C}^*.$$

We shall also suppose that $w_x, w_y > 0$. By analogy to the case of an isolated singularity of a germ of an analytic function [2], we give the following

DEFINITION 1. — A polynomial $f \in \mathbb{K}[x, y]$ is called semiweighted homogeneous (swh) of weighted degree $\text{wdeg}(f) = d$ and type \mathbf{w} if it can be written as

$$f = \sum_{i=0}^d f_i,$$

where f_i are wh-polynomials of weighted degree i and type \mathbf{w} , and the polynomial $f_d(x, y)$ has an isolated critical point at the origin.

Note that according to this definition a wh-polynomial with non-isolated critical point is not semiweighted homogeneous. We define the weighted degree of a one-form $\omega = P dx + Q dy$ as

$$\text{wdeg}(\omega) = \max\{\text{wdeg}(P) + w_x, \text{wdeg}(Q) + w_y\}.$$

The main feature of a swh polynomial is that its global behavior is exactly as the local behavior of its highest order weight-homogeneous part [6]. Using this the following theorem can be proved

THEOREM 1 (see [7]). — *Let $f \in \mathbb{K}[x, y]$ be a swh-polynomial of weighted degree $\text{wdeg}(f) = d$ and type $\mathbf{w} = (w_x, w_y)$. The $\mathbb{K}[t]$ module \mathcal{P}_f is free and finitely generated by μ polynomial one-forms $\omega_1, \omega_2, \dots, \omega_\mu$, where $\mu = (d - w_x)(d - w_y)/w_x w_y$. Each one-form ω_i can be defined by the condition*

$$(2) \quad d\omega_i = g_i dx dy$$

where g_1, g_2, \dots, g_μ is a monomial basis of the quotient ring $\mathbb{K}[x, y]/\langle f_x, f_y \rangle$. For every polynomial one-form ω there exist unique polynomials $a_k(t)$ of degree at most $(\text{wdeg}(\omega) - \text{wdeg}(\omega_k))/\text{wdeg}(f)$ such that in \mathcal{P}_f holds

$$\omega = \sum_{k=1}^{\mu} a_k(t)\omega_k.$$

Remark 1. — In [7] the above theorem was proved for $\mathbb{K} = \mathbb{C}$. In the case $\mathbb{K} = \mathbb{R}$ the proof is the same.

Remark 2. — The number $\mu = (d - w_x)(d - w_y)/w_x w_y$ is the global Milnor number of the polynomial $f(x, y)$: every regular fiber $f^{-1}(t) \subset \mathbb{C}^2$ has the homotopy type of a bouquet of μ circles [6]. It is equal, on another hand, to the global Milnor number of the highest order weight-homogeneous part f^d of the polynomial f . Let g_1, g_2, \dots, g_μ be a monomial basis of the quotient ring $\mathbb{K}[x, y]/\langle f_x^d, f_y^d \rangle$. Then one can show that

- $\sum_{i=1}^{\mu} \text{wdeg}(g_i) = \mu$;
- $\text{wdeg}(g_i) \leq 2(d - w_x - w_y)$;
- g_1, g_2, \dots, g_μ form a basis of the quotient ring $\mathbb{K}[x, y]/\langle f_x, f_y \rangle$.

Remark 3. — Denote by Ω^\bullet the complex of polynomial differential forms on \mathbb{C}^2 and let $\Omega_{\mathbb{C}^2/\mathbb{C}}^\bullet$ be the complex of relative polynomial forms, where

$$\Omega_{\mathbb{C}^2/\mathbb{C}}^k = \frac{\Omega^k}{\Omega^{k-1} \wedge df}.$$

Let $f \in \Omega^0 = \mathbb{C}[x, y]$ be a polynomial with isolated critical points and suppose that $\omega, \pi \in \Omega^1$ represent equivalence classes in the first relative cohomology group of f

$$H^1(\Omega_{\mathbb{C}^2/\mathbb{C}}^\bullet) = \frac{Z(\Omega_{\mathbb{C}^2/\mathbb{C}}^1)}{d\Omega_{\mathbb{C}^2/\mathbb{C}}^0} = \frac{Z(\Omega_{\mathbb{C}^2/\mathbb{C}}^1)}{d\Omega^0 + \Omega^0 df}$$

and in the Petrov module

$$\mathcal{P}_f = \frac{\Omega^1}{d\Omega^0 + \Omega^0 df}$$

respectively. It is easy to check that the identity

$$d\pi = \omega \wedge df$$

defines a \mathbb{K} -linear map

$$[\omega] \mapsto [\pi] : \mathcal{P}_f \longrightarrow H^1(\Omega_{\mathbb{C}^2/\mathbb{C}}^\bullet)$$

which is a bijection. Similarly the map $\omega \mapsto \pi$, where $d\omega = \pi$ establishes a \mathbb{K} -linear bijection

$$[\omega] \mapsto [\pi] : \mathcal{P}_f \longrightarrow \frac{\Omega^2}{d\Omega^0 \wedge df}.$$

The local results of Brieskorn [5] and Sebastiani [28] combined with Theorem 1 suggest the following

CONJECTURE. — *Let $f(x, y) \in \mathbb{K}[x, y]$ be a polynomial with isolated critical points, and such that every fiber $f^{-1}(t)$, $t \in \mathbb{C}$ is regular at infinity (see [21]). Then the $\mathbb{K}[t]$ module \mathcal{P}_f is free and its rank equals the global Milnor number of f .*

3. Milnor bundles.

In this section we suppose that $f \in \mathbb{R}[x, y]$ is a semiweighted homogeneous polynomial. It is well known that the global Milnor fibration

$$(3) \quad \mathbb{C}^2 \xrightarrow{f} \mathbb{C}$$

is locally trivial on the complement to the set of critical values

$$A_c = \{t_1, t_2, \dots, t_\nu\}$$

of f (there are no critical points “at infinity” in this case [6]). To the global Milnor fibration $\mathbb{C}^2 \xrightarrow{f} \mathbb{C}$ we associate the homology (resp. cohomology) Milnor bundle E (resp. E^*). This is a holomorphic vector bundle with base $\mathbb{C} - A_c$ and fibers $E_t = H_1(f^{-1}(t), \mathbb{C})$ (resp. $E_t^* = H^1(f^{-1}(t), \mathbb{C})$). Any two “close” fibers of the global Milnor fibration (3) are isotopic, which shows that any two “close” fibers of the homology Milnor bundle are canonically isomorphic. This isomorphism is called the *Gauss-Manin connection* of the (co)homology Milnor bundle.

Choose a disc $D \subset \mathbb{C}$ containing A_c and let $u_i \subset D$ be paths connecting a fixed point $t_0 \in \partial D$ to t_i . To each path u_i we associate a loop $\ell_i \in \pi_1(D - A_c, t_0)$ and each loop ℓ_i defines an automorphism (*monodromy*)

$$\ell_{i*}: H_1(f^{-1}(t_0), \mathbb{Z}) \longrightarrow H_1(f^{-1}(t_i), \mathbb{Z}).$$

Denote by

$$H_i \subset H_1(f^{-1}(t_0), \mathbb{C})$$

the vector space formed by cycles which vanish at the critical value t_i as $t \rightarrow t_i$ along the path u_i (see the beginning of the section).

DEFINITION 2. — *The set of planes H_1, H_2, \dots, H_ν is called a weekly distinguished basis of vanishing planes, provided that the fundamental group $\pi_1(D - A_c, t_0)$ is freely generated by the loops $\ell_1, \ell_2, \dots, \ell_\nu$.*

DEFINITION 3. — *The image of the fundamental group $\pi_1(D - A_c, t_0)$ in $\text{Aut}(H_1(f^{-1}(t_0)))$ is called the monodromy group of the global homology Milnor bundle of the polynomial $f(x, y)$ and it will be denoted by \mathbf{M} .*

It is well known that the vanishing cycles form a basis of the middle homology group of an isolated singularity [2]. Combining this with the results of [6] implies the following direct sum decomposition

$$(4) \quad H_1(f^{-1}(t_0), \mathbb{C}) = \bigoplus_{i=1}^{\nu} H_i.$$

The global Milnor bundle E is equipped with the following structures:

1) Each fiber $E_t = H_1(f^{-1}(t), \mathbb{C})$ of the homology Milnor bundle E contains a real vector space $H_1(f^{-1}(t), \mathbb{R})$ and a lattice $H_1(f^{-1}(t), \mathbb{Z})$.

2) On each fiber $E_t = H_1(f^{-1}(t), \mathbb{C})$ we have an integer skew-symmetric bi-linear form $\langle \cdot, \cdot \rangle$: the intersection index of cycles on the affine curve $f^{-1}(t) \subset \mathbb{C}^2$. The intersection form $\langle \cdot, \cdot \rangle_{|E_t}$ is invariant under parallel transport, and in particular $\langle \cdot, \cdot \rangle_{|E_t}$ is invariant under the action of the monodromy group \mathbf{M} .

3) The complex conjugation $(x, y, t) \rightarrow (\bar{x}, \bar{y}, \bar{t})$ induces an involution on $H_1(f^{-1}(t), \mathbb{C})$ for $t \in \mathbb{R}$, and an anti-holomorphic involution of the Milnor bundle E

$$(5) \quad E_t \longrightarrow E_{\bar{t}} : \gamma(t) \longmapsto \overline{\gamma(\bar{t})}.$$

In particular, $\bar{E}_t = E_t$ for $t \in \mathbb{R}$ and (5) is an automorphism.

The intersection form $\langle \cdot, \cdot \rangle$ in the fibers E_t is degenerate in general. Let Γ_t be the compactified and normalized affine algebraic curve $f^{-1}(t) \subset \mathbb{C}^2$. We have a natural inclusion

$$i: f^{-1}(t) \longrightarrow \Gamma_t.$$

The kernel of the intersection form $\langle \cdot, \cdot \rangle$ on $H_1(f^{-1}(t), \mathbb{C})$ coincides with the kernel of the induced map

$$i_*: H_1(f^{-1}(t), \mathbb{C}) \longrightarrow H_1(\Gamma_t, \mathbb{C}).$$

PROPOSITION 1. — *The cycle $\delta(t_0)$ is a fixed point of the monodromy group \mathbf{M} , if and only if $\delta(t_0)$ belongs to the kernel of the intersection form $\langle \cdot, \cdot \rangle$.*

Indeed, if $\delta(t_0)$ belongs to the kernel of the intersection form, then the Picard-Lefschetz formula implies that

$$\mathbf{M} \cdot \delta(t_0) = \delta(t_0).$$

If $\mathbf{M} \cdot \delta(t_0) = \delta(t_0)$ then we may choose a loop $\ell \in \pi_1(D - A_c, t_0)$ which makes one turn about all critical values of f . Then ℓ_* is the operator of classical monodromy of the weighted homogeneous singularity f^d (where f^d is the highest order weight homogeneous part of f). In this case we have

$$\ell_* - \text{id} = \text{Var}_{f^d} \circ i_*$$

and as $\text{Var}_{f^d} |_{H_1(\Gamma_t, \mathbb{C})}$ is injective, then the kernel of $\ell_* - \text{id}$ is the set of cycles which are homologous to zero on Γ_t (equivalently, whose relative homology class is zero) [2]. Therefore $\delta(t_0)$ belongs to the kernel of the intersection form $\langle \cdot, \cdot \rangle$. □

For any locally constant section $\delta(t) \subset H_1(f^{-1}(t), \mathbb{Z})$ of the homology Milnor bundle E denote by

$$E_{\delta(t_0)} \subset E_{t_0} = H_1(f^{-1}(t_0), \mathbb{C})$$

the minimal complex vector space containing the orbit $\mathbf{M} \cdot \delta(t_0)$. This gives rise to a flat complex sub-bundle E_δ of the homology Milnor bundle E , whose fibers $E_{\delta(t)}$ are obtained from $E_{\delta(t_0)}$ by parallel transport. The holomorphic bundle E_δ carries the structures 1) and 2) above. By analogy to (5) we give the following

DEFINITION 4. — *The bundle E_δ is said to be compatible with the real structure (the antiholomorphic involution) of E , provided that*

$$\overline{E_{\delta(t)}} = E_{\delta(\bar{t})}, \quad \forall t \in \mathbb{C}.$$

PROPOSITION 2. — *Suppose that the cycle $\delta(t_0)$ is obtained from some real cycle $\delta(t)$ (that is to say $\bar{\delta}(t) = \delta(t)$, $t \in \mathbb{R}$) by parallel transport. Then E_δ is compatible with the real structure of the complex bundle E .*

Proof. — Suppose that $\delta(t_0)$ is obtained from the real cycle $\delta(t)$, $t \in \mathbb{R}$ by parallel transport, and let $\gamma(t)$ be another cycle obtained by parallel transport along some path u (the ends of u coincide with t , $u \subset \mathbb{C} - A_c$). The identity

$$\int_{\overline{\gamma(t)}} \omega = \int_{\bar{\gamma}(\bar{t})} \omega$$

implies that the cycle $\bar{\gamma}(t)$ is obtained from $\delta(t)$ by parallel transport along the path \bar{u} , and hence $\gamma(t), \bar{\gamma}(t) \in E_t, t \in \mathbb{R}$. As a set of generators of E_t can be obtained in such a way, we conclude that $\overline{E_{\delta(t)}} = E_{\delta(t)}$. In a similar way we prove that $\overline{E_{\delta(t)}} = E_{\delta(\bar{t})}$ for all $t \in \mathbb{C}$. □

DEFINITION 5. — We shall say that the bundle E_δ satisfies the condition (\star) provided that the following direct sum decomposition holds:

$$(\star) \quad E_{\delta(t_0)} = \bigoplus_{i=1}^{\nu} \{H_i \cap E_{\delta(t_0)}\}.$$

The condition (\star) is motivated by the direct sum decomposition (4). Of course the decomposition (4) holds for any choice of the paths u_i . Similarly, the condition (\star) does not depend on the choice of the paths u_i (and hence on the choice of vanishing planes H_i), as it follows from the following simple

PROPOSITION 3. — The bundle E_δ satisfies the condition (\star) , if and only if

$$\delta(t_0) = \sum_i \delta_i(t_0), \quad \text{where } \delta_i(t_0) \in H_i \cap E_{\delta(t_0)}.$$

COROLLARY 1. — If $\delta(t)$ is a vanishing cycle (along an appropriate path connecting t to a singular value t_i) then the bundle E_δ satisfies the condition (\star) .

Proof of Proposition 3. — It suffices to prove that if $\gamma(t_0) \in E_{\delta(t_0)}$, then

$$(6) \quad \gamma(t_0) = \sum_{i=1}^{\nu} \gamma_i(t_0) \quad \text{where } \gamma_i(t_0) \in H_i \cap E_{\delta(t_0)}.$$

If $\ell_{j*} \in \text{Aut}(H_1(f^{-1}(t_0)))$ is the monodromy transformation induced by the loop ℓ_j then the Picard-Lefschetz formula [2] shows that

$$\ell_{j*}\delta(t_0) = \delta(t_0) + \alpha(t_0), \quad \alpha(t_0) \in \{H_j \cap E_{\delta(t_0)}\},$$

and hence $\gamma(t_0) = \ell_{j*}\delta(t_0)$ satisfies (6). The identity (6) follows from the fact that $\mathbf{M} \cdot \delta(t_0)$ generates $E_{\delta(t_0)}$. \square

To check that the condition (\star) does not depend on the choice of paths u_i , we have to prove that if we replace the plane H_i by $\ell_{j*}H_i$, then the identity of Proposition 3 still holds true. Indeed, as

$$\ell_{j*}\delta_i(t_0) = \delta_i(t_0) + \alpha_j(t_0),$$

where $\alpha_j(t_0) \in \{H_i \cap E_{\delta(t_0)}\}$, then

$$\delta(t_0) = \sum_{k \neq i, j} \delta_k(t_0) + \ell_{j*} \delta_i(t_0) - \alpha_j(t_0) + \delta_j(t_0)$$

where $\ell_{j*} \delta_i(t_0) \in \ell_{j*} H_i \cap E_{\delta(t_0)}$ and $-\alpha_j(t_0) + \delta_j(t_0) \in \{H_j \cap E_{\delta(t_0)}\}$.

Another important case in which the condition (\star) is satisfied is given by the following

PROPOSITION 4. — *If \mathbf{M} acts on $E_{\delta(t_0)}$ without fixed points then the bundle E_δ satisfies the condition (\star) .*

Proof. — We have

$$\text{Im}(\ell_{j*} - \text{id})|_{E_{\delta(t_0)}} \subset H_j \cap E_{\delta(t_0)}$$

and hence

$$(7) \quad \sum_j \dim \{ \text{Im}(\ell_{j*} - \text{id})|_{E_{\delta(t_0)}} \} \leq \dim E_{\delta(t_0)}.$$

On the other hand

$$\dim \{ \text{Im}(\ell_{j*} - \text{id})|_{E_{\delta(t_0)}} \} = \dim E_{\delta(t_0)} - \dim \{ \text{Ker}(\ell_{j*} - \text{id})|_{E_{\delta(t_0)}} \},$$

$$\begin{aligned} & \dim \{ \text{Im}(\ell_{(j+1)*} - \text{id})|_{E_{\delta(t_0)}} \} \\ & \geq \dim \{ \text{Im}(\ell_{(j+1)*} - \text{id})|_{\text{Ker}(\ell_{j*} - \text{id})|_{E_{\delta(t_0)}}} \} \\ & = \dim \{ \text{Ker}(\ell_{j*} - \text{id})|_{E_{\delta(t_0)}} \} \\ & \quad - \dim [\{ \text{Ker}(\ell_{(j+1)*} - \text{id})|_{E_{\delta(t_0)}} \} \cap \{ \text{Ker}(\ell_{j*} - \text{id})|_{E_{\delta(t_0)}} \}] \end{aligned}$$

and hence

$$(8) \quad \sum_j \dim \{ \text{Im}(\ell_{j*} - \text{id})|_{E_{\delta(t_0)}} \} \geq \dim E_{\delta(t_0)} - \dim \{ \bigcap_i \text{Ker}(\ell_{i*} - \text{id})|_{E_{\delta(t_0)}} \}.$$

As \mathbf{M} acts on $E_{\delta(t_0)}$ without fixed points, then

$$\bigcap_i \text{Ker}(\ell_{i*} - \text{id})|_{E_{\delta(t_0)}} = \emptyset,$$

which combined with (7), (8) gives

$$E_{\delta(t_0)} = \bigoplus_{j=1}^{\nu} \{ \text{Im}(\ell_{j*} - \text{id})|_{E_{\delta(t_0)}} \}$$

and hence (\star) . □

4. Abelian integrals related to Morse polynomials.

Denote by \mathcal{A}_δ the vector space of Abelian integrals

$$(9) \quad I(t) = \int_{\delta(t)} \omega$$

over all polynomial one-forms

$$\omega = P(x, y) dx + Q(x, y) dy, \quad P, Q \in \mathbb{R}[x, y].$$

This is a $\mathbb{R}[t]$ module with multiplication

$$t \cdot \int_{\delta(t)} \omega = \int_{\delta(t)} f(x, y) \omega.$$

The map

$$(10) \quad \mathcal{P}_f \longrightarrow \mathcal{A}_\delta : \omega \longmapsto \int_{\delta(t)} \omega$$

is a homomorphism of $\mathbb{R}[t]$ modules. In the case when f is a polynomial with Morse critical points and distinct critical values, the map (10) is an isomorphism [7], Prop. 3.2, and $E_{\delta(t)} = E_t = H_1(f^{-1}(t), \mathbb{C})$. In the case of multiple critical values, however, E_δ may be a proper subbundle of the homology Milnor bundle E .

In the sequel we shall call $\delta(t_0) \in H_1(f^{-1}(t_0), \mathbb{Z})$ a *vanishing cycle* provided that it vanishes along some path u_i as $t \rightarrow t_i$. Note that this is less restrictive than the usual definition [2] (as we do not use “morsification” of f). Recall that a cycle $\delta(t)$, $t \in \mathbb{R}$ is said to be *real*, provided that $\bar{\delta}(t) = \delta(t)$.

The central result of the present paper is the following

THEOREM 2. — *Suppose that the semiweighted homogeneous polynomial $f \in \mathbb{R}[x, y]$ has only Morse critical points. If the vector bundle E_δ is compatible with the real structure of the Milnor bundle E , and satisfies the condition (\star) , then the $\mathbb{R}[t]$ module \mathcal{A}_δ is free, finitely generated, and its rank is equal to the rank of E_δ .*

COROLLARY 2. — *Suppose that the semiweighted homogeneous polynomial $f \in \mathbb{R}[x, y]$ has only Morse critical points. If $\delta(t)$ is a real vanishing cycle, then the $\mathbb{R}[t]$ module \mathcal{A}_δ is free, finitely generated, and its rank is equal to the rank of the complex vector bundle E_δ .*

Remark 4. — As the map (10) is surjective, the generators of \mathcal{A}_δ may be chosen among the integrals over monomial one-forms

$$I_j(t) = \int_{\delta_i(t)} \omega_j, \quad j = 1, 2, \dots, \mu,$$

where ω_j is the basis of \mathcal{P}_f defined in Theorem 1.

Proof of Corollary 2. — If the cycle $\delta(t)$, $t \in \mathbb{R}$ is real, then by Proposition 2 the bundle E_δ is compatible with the real structure of E . If the cycle $\delta(t)$ vanishes along some path connecting t to a critical value of f , then by Corollary 1 the bundle satisfies the condition (\star) . The result follows from Theorem 2. □

The proof of Theorem 2 is based on the following

LEMMA 1. — Let $\delta'_1, \delta'_2, \dots, \delta'_{\mu'}$ be a basis of locally constant sections of E_δ . There exists a permutation $\sigma' = (\sigma'_1, \sigma'_2, \dots, \sigma'_{\mu'})$, such that

$$\det \left(\int_{\delta'_j(t)} \nabla \omega_{\sigma'_i} \right)$$

is a non-zero constant in t , where ∇ is the covariant derivative with respect to the Gauss-Manin connection of E , and

$$\sum_{i=1}^{\mu'} \text{wdeg } \omega_{\sigma'_i} = \mu' \text{wdeg}(f).$$

Proof of Theorem 2 assuming the above lemma. — As f is a sw-h-polynomial (Def. 1) then we may deduce that for sufficiently big $|t|$, such that the argument of t is bounded, holds

$$\left| \frac{\int_{\delta'_j(t)} \omega_{\sigma'_i}}{t \int_{\delta'_j(t)} \nabla \omega_{\sigma'_i}} \right| = O(1)$$

(see the proof of Lemma 2.2 in [7]). This implies that for sufficiently big $|t|$

$$\left| \frac{\det(\int_{\delta'_j(t)} \omega_{\sigma'_i})}{t^{\mu'} \det(\int_{\delta'_j(t)} \nabla \omega_{\sigma'_i})} \right| = O(1)$$

and hence

$$p_0(t) = \det \left(\int_{\delta'_j(t)} \omega_{\sigma'_i} \right)$$

is a polynomial of degree exactly $\mu' = \text{rank } E_\delta$. By (\star) , we have

$$E_{\delta(t_0)} = \bigoplus_i \{E_{\delta(t_0)} \cap H_i\}$$

and hence

$$\text{deg } p_0(t) = \sum \dim\{E_{\delta(t_0)} \cap H_i\}.$$

As f has only Morse critical points, then $p_0(t)$ has a zero of order $\dim\{E_{\delta(t_0)} \cap H_i\}$ at $t = t_i$, and hence

$$p_0(t) = C^{\text{te}} \prod_{i=1}^{\mu'} (t - t_i)^{\dim\{E_{\delta(t_0)} \cap H_i\}}.$$

In particular $p_0(t)$ does not vanish for $t \neq t_i$. If ω is a polynomial one-form, then the Cramer's formulae imply that there exist polynomials $p_i(t)$, such that

$$(11) \quad p_0(t) \int_{\delta(t)} \omega = \sum_{i=1}^{\mu} p_i(t) \int_{\delta(t)} \omega_{\sigma'_i}, \quad \forall \delta(t) \in E_{\delta(t)}.$$

Each polynomial $p_i(t)$ has a zero of order $\dim\{E_{\delta(t_0)} \cap H_i\}$ at $t = t_i$, and hence the polynomial $p_0(t)$ divides $p_i(t)$. It remains to check that $p_i(t)/p_0(t)$ is a *real* polynomial. As E_δ is compatible with the real structure of the Milnor bundle E , then the complex conjugation $\gamma(t) \mapsto \bar{\gamma}(\bar{t})$ induces an automorphism $a \in \text{Aut}(E_{\delta(t)})$ for $t \in \mathbb{R}$. It follows that

$$\overline{p_i(t)} = \det(a) p_i(t)$$

and hence $p_i(t)/p_0(t) \in \mathbb{R}[t]$. □

Proof of Lemma 1 in the case when the intersection form $\langle \cdot, \cdot \rangle$ is non-degenerate. — Let E_δ^\perp be the vector sub-bundle of E with fibers

$$E_{\delta(t)}^\perp = \{ \gamma(t) \in E_t : \langle \gamma(t), \delta(t) \rangle = 0, \forall \delta(t) \in E_{\delta(t)} \}.$$

As the intersection form on E_t is non-degenerate, then by Proposition 1 and Proposition 4 the bundles E_δ and E_δ^\perp satisfy the condition (\star) . We

claim further that $\langle \cdot, \cdot \rangle|_{E_{\delta(t_0)}}$ is non-degenerate. Indeed, if we suppose that $\gamma(t_0) \in E_{\delta(t_0)}$, $\gamma(t_0) \neq 0$, then there exists a vanishing cycle $\gamma'(t_0) \in H_i$, such that $\langle \gamma(t_0), \gamma'(t_0) \rangle \neq 0$. The Picard-Lefschetz formula gives

$$\ell_{i*}\gamma(t_0) = \gamma(t_0) - \sum_j \langle \gamma(t_0), \gamma'_j(t_0) \rangle \gamma'_j(t_0)$$

where $\gamma'_j(t_0)$ form a basis of H_i . As

$$\langle \ell_{i*}\gamma(t_0), \gamma(t_0) \rangle = \sum_j \langle \gamma(t_0), \gamma'_j(t_0) \rangle^2 \geq \langle \gamma(t_0), \gamma'(t_0) \rangle^2 \neq 0$$

and $\ell_{i*}\gamma(t_0) \in E_{\delta(t_0)}$, then we conclude that $\langle \cdot, \cdot \rangle|_{E_{\delta(t_0)}}$ is non-degenerate. On its hand this implies that

$$(12) \quad E = E_{\delta} \oplus E_{\delta}^{\perp}.$$

Let $\sigma = (\sigma', \sigma'')$ be a permutation of the set $\{1, 2, \dots, \mu\}$ such that

$$\begin{aligned} \sigma' &= (\sigma'_1, \sigma'_2, \dots, \sigma'_{\mu'}), & \sigma'' &= (\sigma''_1, \sigma''_2, \dots, \sigma''_{\mu''}), \\ \sigma'_i &< \sigma'_{i+1}, & \sigma''_i &< \sigma''_{i+1} \end{aligned}$$

and $\mu' = \dim E_{\delta(t_0)}$, $\mu'' = \dim E_{\delta(t_0)}^{\perp}$. Let $\omega_1, \omega_2, \dots, \omega_{\mu}$ be a “monomial” base of the Petrov module \mathcal{P}_f defined by (2), $\delta' = (\delta'_1, \delta'_2, \dots, \delta'_{\mu'})$, $\delta'' = (\delta''_1, \delta''_2, \dots, \delta''_{\mu''})$ be fixed bases of $E_{\delta(t_0)}$ and $E_{\delta(t_0)}^{\perp}$ respectively, $\delta = (\delta', \delta'')$. Denote by

$$\left(\int_{\delta_j} \nabla \omega_i \right), \quad \left(\int_{\delta'_j} \nabla \omega_{\sigma'_i} \right), \quad \left(\int_{\delta''_j(t)} \nabla \omega_{\sigma''_i} \right)$$

the matrices of dimension $\mu \times \mu$, $\mu' \times \mu'$, and $\mu'' \times \mu''$ respectively. The Picard-Lefschetz formula implies that the functions

$$\Delta(t) = \det \left(\int_{\delta_j} \nabla \omega_i \right), \quad \Delta_{\sigma'}(t) = \det \left(\int_{\delta'_j} \nabla \omega_{\sigma'_i} \right)$$

and

$$\Delta_{\sigma''}(t) = \det \left(\int_{\delta''_j(t)} \nabla \omega_{\sigma''_i} \right)$$

are single-valued on \mathbb{C} , and hence they are rational functions. On the other hand each integral $\int_{\delta_j} \nabla \omega_i$ can have only logarithmic singularities (as the

critical points of f are of Morse type) so the above determinants are in fact polynomials. We have

$$(13) \quad \Delta(t) = \sum_{\sigma} \Delta_{\sigma'}(t) \Delta_{\sigma''}(t)$$

where the sum is over all the permutations $\sigma = (\sigma', \sigma'')$ as above. It is proved in [7] that $\Delta(t)$ is a non-zero constant, and

$$\sum_{i=1}^{\mu} \text{wdeg } \omega_i = \sum_{i=1}^{\mu'} \text{wdeg } \omega_{\sigma'_i} + \sum_{i=1}^{\mu''} \text{wdeg } \omega_{\sigma''_i} = \mu \text{ wdeg}(f).$$

As

$$\deg \Delta_{\sigma'}(t) \leq \frac{\sum_{i=1}^{\mu'} \text{wdeg } \omega_{\sigma'_i}}{\text{wdeg}(f)} - \mu', \quad \deg \Delta_{\sigma''}(t) \leq \frac{\sum_{i=1}^{\mu''} \text{wdeg } \omega_{\sigma''_i}}{\text{wdeg}(f)} - \mu'',$$

then

$$\deg \Delta_{\sigma'}(t) + \deg \Delta_{\sigma''}(t) \leq 0.$$

This implies that for any permutation $\sigma = (\sigma', \sigma'')$ the polynomial $\Delta_{\sigma'}(t)\Delta_{\sigma''}(t)$ is either a non-zero constant, or it is identically zero. We conclude that there exists a permutation $\sigma = (\sigma', \sigma'')$, such that the polynomial $\Delta_{\sigma'}(t)\Delta_{\sigma''}(t)$ is a non-zero constant.

Proof of Lemma 1 in the case when the intersection form $\langle \cdot, \cdot \rangle$ is degenerate. — Let Γ_t be the compactified and normalized affine curve $f^{-1}(t)$. We have

$$H_1(\Gamma_t, \mathbb{C}) = H_1(f^{-1}(t), \mathbb{C}) / \sim$$

where $\delta(t) \sim 0$ if and only if $\delta(t)$ is in the kernel of the intersection form on $H_1(f^{-1}(t), \mathbb{C})$. Denote

$$\tilde{E} = E / \sim, \quad \tilde{E}_{\delta} = E_{\delta} / \sim, \quad \tilde{E}_{\delta}^{\perp} = E_{\delta}^{\perp} / \sim, \quad \tilde{H}_i = H_i / \sim.$$

As the intersection form is non-degenerate on $H_1(\Gamma_t, \mathbb{C})$ then as above we obtain

$$H_1(\Gamma_t, \mathbb{C}) = \tilde{E}_{\delta(t)} \oplus \tilde{E}_{\delta(t)}^{\perp}, \quad \tilde{E}_{\delta(t_0)} = \bigoplus_{i=1}^{\nu} \{ \tilde{H}_i \cap \tilde{E}_{\delta(t_0)} \},$$

$$\tilde{E}_{\delta(t_0)}^{\perp} = \bigoplus_{i=1}^{\nu} \{ \tilde{H}_i \cap \tilde{E}_{\delta(t_0)}^{\perp} \}.$$

We already know that

$$\Delta_{\sigma}(t) = \det \left(\int_{\delta_j(t)} \nabla \omega_{\sigma_i} \right)$$

is a non-zero constant [7]. On the other hand if the cycle $\delta(t)$ is homologous to zero on the compactified and normalized fibre $f^{-1}(t)$, then

$$\int_{\delta(t)} \nabla\omega_j$$

is a polynomial in t which is a linear combination of the residues of $\nabla\omega_j$. By Remark 2 the weighted degree of $\nabla\omega_j$ is less than d and hence $|\int_{\delta(t)} \nabla\omega_j|$ grows at infinity no faster than a constant. By making use of \mathbb{R} -linear change of the base $(\omega_1, \omega_2, \dots, \omega_\mu)$ and \mathbb{C} -linear change of the base $(\delta_1, \delta_2, \dots, \delta_\mu)$ we may partially diagonalize the $\mu \times \mu$ matrix $(\int_{\delta_j} \nabla\omega_{\sigma_i})$:

$$(14) \quad \left(\int_{\delta_j} \nabla\omega_{\sigma_i} \right) = \begin{pmatrix} A & * \\ 0 & I_{\mu-2g} \end{pmatrix}, \quad I_{\mu-2g} = \text{diag}(1, 1, \dots, 1),$$

where g is the genus of the compact Riemann surface Γ_t , and A is a $2g \times 2g$ matrix. The first $2g$ lines of the matrix (14) correspond to integrals over cycles which form a base of $H_1(\Gamma_t, \mathbb{C})$, and the last $\mu - 2g$ lines of the matrix (14) correspond to integrals over cycles homologous to zero on Γ_t . Respectively the one-forms $\omega_1, \omega_2, \dots, \omega_{2g}$ have no residues on Γ_t , and each of the remaining $\mu - 2g$ one-forms is a normalized differential of third kind. This new base of one-forms is no-more monomial but each one-form can still be still chosen weighted homogeneous.

We notice now that $\det A = \Delta_\sigma(t)$, and hence $\det A$ is a non-zero constant. As in the case of a non-degenerate intersection form, we can find weighted homogeneous (and hence also monomial) one-forms without residues, such that the determinant of the corresponding rank $\tilde{E}_\delta \times \tilde{E}_\delta$ is a non-zero constant. Complete at last the basis of sections of \tilde{E}_δ to a basis of sections of E_δ by adding zero-homology cycles, as well the basis of first kind forms by adding normalized third kind forms. The determinant of the obtained in this way rank $E_\delta \times \text{rank } E_\delta$ matrix is a non-zero constant, which completes the proof of Lemma 1. □

5. Polynomial perturbations of conservative vector fields.

Consider the differential equation

$$(15) \quad dH + \varepsilon\omega + o(\varepsilon) = 0, \quad |\varepsilon| \ll 1$$

where $H(x, y) = \frac{1}{2}(x^2 + y^2) + \dots$ is a real polynomial, $\omega, o(\varepsilon)$ are polynomial

one-forms on \mathbb{R}^2 , and the norm of $o(\varepsilon)/\varepsilon$ tends to zero on any compact domain $K \subset \mathbb{R}^2$, as $\varepsilon \rightarrow 0$. Let ℓ be a closed arc transversal to a continuous family $\{H = h\}$ of closed integral curves of the equation $dH = 0$, and parameterized by $h = H(x, y)|_\ell$. Denote by $P_\varepsilon(h)$ be the corresponding first return map associated to (15) and to the arc ℓ (see Fig. 1). The limit cycles of (15) intersecting ℓ are in one-to-one correspondence with the zeros of $P_\varepsilon(h) - h$. The basic tool in their study is the following

LEMMA 2. — *One has*

$$P_\varepsilon(h) = h - \varepsilon I(h) + o(\varepsilon), \quad \text{where} \quad I(h) = \int_{\{H=h\}} \omega.$$

For a proof see [25] or [4], p. 318. Lemma 2 implies immediately the following

COROLLARY 3 (Poincaré-Pontryagin criterion). — *If a limit cycle of (15) tends to the closed integral curve $\{H = h_0\}$, as $\varepsilon \rightarrow 0$, then $I(h_0) = 0$. If $I(h_0) = 0$ and in addition $I'(h_0) \neq 0$, then for all sufficiently small $|\varepsilon| \neq 0$ the equation (15) has an unique limit cycle which tends to $\{H = h_0\}$ as $\varepsilon \rightarrow 0$.*

For every fixed sufficiently small $|\varepsilon|$ the first return map $P_\varepsilon(h)$ is an analytic function in a neighborhood of $h = h_0 \neq 0$, and hence it can be analytically continued in a complex domain, $h \in \mathbb{C}$. As the complex zeros of $(P_\varepsilon(h) - h)/\varepsilon$ in a neighborhood of $h = h_0$ depend continuously on ε then we get

COROLLARY 4. — *Suppose that k limit cycles of (15) tend to $\{H = h_0\}$ as $\varepsilon \rightarrow 0$. Then the Abelian integral $I(h)$ has a zero at $h = h_0$ of multiplicity at least k .*

Finally we note that the Poincaré-Pontryagin function $I(h)$ contains an information for the limit cycles which tend to the origin

COROLLARY 5. — *Suppose that k limit cycles of (15) tend to the non-degenerate center $0 \in \mathbb{R}^2$ as $\varepsilon \rightarrow 0$. Then $I(h)$ has a zero at $h = 0$ of multiplicity at least $k + 1$.*

Proof. — Without loss of generality we assume that $0 \in \mathbb{R}^2$ is a non-degenerate singular point of (15) for all sufficiently small $|\varepsilon|$. Indeed, if the coordinates of the singular point are $(a(\varepsilon), b(\varepsilon))$, where $a(0) = b(0) = 0$, then we substitute

$$x \rightarrow x + a(\varepsilon), \quad y \rightarrow y + b(\varepsilon)$$

in (15). The Poincaré-Pontryagin function of the new differential equation coincides with the Poincaré-Pontryagin function of (15). Let ℓ be a smooth closed arc through the origin in \mathbb{R}^2 , and transversal to the periodic solutions $\{H = h\}$ in a small neighborhood of the center. It is parameterized by the analytic function $\rho = \sqrt{H(x, y)}|_{\ell}$. It is classically known that the associate first return map $\tilde{P}_{\varepsilon}(\rho)$ is an analytic function. Each limit cycle of (15) which is close to the origin, intersects twice $\tilde{\ell}$. As $\tilde{P}_{\varepsilon}(0) = 0$ then it follows that if k limit cycles of the equation (15) tend to the origin in \mathbb{R}^2 as $\varepsilon \rightarrow 0$, then $\tilde{P}_{\varepsilon}(\rho) - \rho$ has at least $2k + 1$ real zeros in a neighborhood of the origin $\rho = 0$ on ℓ . As before we may continue analytically the function $\tilde{P}_{\varepsilon}(\rho) - \rho$ in a complex domain $\rho \in \mathbb{C}$. The zeros of $(\tilde{P}_{\varepsilon}(\rho) - \rho)/\varepsilon$ depend continuously on ε and hence the Poincaré-Pontryagin function

$$\tilde{I}(\rho) = \lim_{\varepsilon \rightarrow 0} \frac{\tilde{P}_{\varepsilon}(\rho) - \rho}{\varepsilon}$$

has a zero of multiplicity at least $2k + 1$ at $\rho = 0$. We note at last that

$$dH + \varepsilon\omega + o(\varepsilon) = 0 \iff d\rho + \varepsilon \frac{\tilde{\omega}}{2\rho} + \frac{o(\varepsilon)}{2\rho} = 0, \quad \rho^2 = H.$$

Repeating the arguments from the proof of Lemma 2 in a punctured neighborhood of the origin in \mathbb{R}^2 we obtain

$$\tilde{I}(\rho) = \frac{I(h)}{2\rho}, \quad I(h) = \int_{\{H=h\}} \omega.$$

As the Abelian integral $I(h)$ is analytic in $h = \rho^2$, then $\tilde{I}(\rho)$ is an odd function and $I(h)$ has a zero at the origin of multiplicity at least $k + 1$ in h . \square

6. Abelian integrals which arise in polynomial perturbations of quadratic Hamiltonian vector fields with a center.

The quadratic polynomial vector fields with a center can be divided in four classes: Q_3^{LV} , Q_3^H , Q_3^R and Q_4 (Zoladek [30]), called Lotka-Volterra case, Hamiltonian case, reversible case and codimension 4 case respectively. In this section we shall study the Poincaré-Pontryagin functions

$$\begin{aligned} I(h) &= \int_{\{H=h\}} P(x, y) dy - Q(x, y) dx \\ &= \iint_{\{H \leq h\}} (P_x(x, u) + Q_y(x, y)) dx \wedge dy, \quad P, Q \in \mathbb{R}[x, y] \end{aligned}$$

associate to small polynomial perturbations of quadratic polynomial Hamiltonian vector fields with a center

$$(16) \quad \dot{x} = \frac{\partial H}{\partial y} + \varepsilon P + o(\varepsilon), \quad \dot{y} = -\frac{\partial H}{\partial x} + \varepsilon Q + o(\varepsilon).$$

If we place the center at the origin and a saddle point at $(1, 0)$, the Hamiltonian function $H(x, y)$ can be written in the following form [13]:

$$(17) \quad H(x, y) = \frac{1}{2}(x^2 + y^2) - \frac{1}{3}x^3 + axy^2 + \frac{1}{3}by^3.$$

The critical values of H are $h_1 = 0$, $h_2 = \frac{1}{6}$, and the roots of the polynomial

$$\begin{aligned} \Delta(h) &= 36(-b^2 + 4a^3)^2 h^2 \\ &\quad - (144a^4 - 48a^3 - 72a^2b^2 - 36ab^2 - 12b^2 - 6b^4)h \\ &\quad + 9a^2 + 6a + b^2 + 1. \end{aligned}$$

The discriminant of $\Delta(h)$ is

$$36(8a^2 + 4a + b^2)^3 b^2$$

and we have also

$$\Delta\left(\frac{1}{6}\right) = (2a + 1)^3((1 + 2a)(1 - a)^2 - b^2), \quad \Delta(0) = (3a + 1)^2 + b^2.$$

The Hamiltonian vector field (16) (resp. the Hamiltonian function H (17)), is said to be reversible, or belongs to Q_3^R , if it has an axis of symmetry. The Hamiltonian $H(x, y)$ (17) is reversible if and only if

$$b((1 + 2a)(1 - a)^2 - b^2) = 0$$

(see [13], Fig. 1, where the non-reversible Hamiltonians with a center were called “generic”). To state our results we shall use the following standard notations introduced in [13], [12]

$$\begin{aligned} X(h) &= \iint_{H \leq h} x \, dx \wedge dy, & Y(h) &= \iint_{H \leq h} y \, dx \wedge dy, \\ M(h) &= \iint_{H \leq h} dx \wedge dy, & L(h) &= \iint_{H \leq h} x^2 \, dx \wedge dy, \\ K(h) &= \iint_{H \leq h} xy \, dx \wedge dy, \\ \omega_X &= -xy \, dx, & \omega_Y &= -\frac{1}{2}y^2 \, dx, & \omega_M &= -y \, dx, \\ \omega_L &= -x^2y \, dx, & \omega_K &= -\frac{1}{2}xy^2 \, dx. \end{aligned}$$

Denote by

$$\delta(h) \subset \{(x, y) \in \mathbb{R}^2 : H(x, y) = h\}$$

the continuous family of ovals surrounding the origin in \mathbb{R}^2 , by \mathcal{A}_δ the real vector space of Abelian integrals of the form

$$\int_{\delta(h)} P(x, y) \, dy - Q(x, y) \, dx, \quad P, Q \in \mathbb{R}[x, y], \quad h \in [h_1, h_2]$$

and by $\mathcal{A}_n \subset \mathcal{A}_\delta$ its subspace formed by Abelian integrals of degree n , where $\deg P, \deg Q \leq n$.

6.1. Generic quadratic Hamiltonian vector fields with a center.

In this section we suppose that the real polynomial $H(x, y)$ defined by (17) is not reversible (equivalently $b((1 + 2a)(1 - a)^2 - b^2) \neq 0$).

PROPOSITION 5.

(i) *The $\mathbb{R}[h]$ modules \mathcal{P}_H and \mathcal{A}_δ are free. The map*

$$(18) \quad \mathcal{P}_H \longrightarrow \mathcal{A}_\delta : \omega \longmapsto \int_{\delta(h)} \omega$$

is an isomorphism of modules.

(ii) If $b^2 - 4a^3 \neq 0$, then the module \mathcal{P}_H is freely generated by $\omega_X, \omega_Y, \omega_M, \omega_K$. If $b^2 - 4a^3 = 0$ the module \mathcal{P}_H is freely generated by $\omega_X, \omega_Y, \omega_M$.

(iii) The real vector space \mathcal{A}_n is of dimension $[\frac{1}{3}(4n + 1)]$.

Proof. — If $b^2 - 4a^3 \neq 0$ the polynomial

$$H^0(x, y) = -\frac{1}{3}x^3 + axy^2 + \frac{1}{3}by^3$$

has an isolated critical point. It follows that

$$\mathbb{C}[x, y]/\langle H_x, H_y \rangle = \mathbb{C}[x, y]/\langle H_x^0, H_y^0 \rangle = \text{Vect}\{1, x, y, xy\}$$

and Theorem 1 implies that \mathcal{P}_H is freely generated by $\omega_X, \omega_Y, \omega_M, \omega_K$. In the case $b^2 - 4a^3 = 0$ the polynomial $-\frac{1}{3}x^3 + axy^2 + \frac{1}{3}by^3$ has non-isolated critical points and after a real linear change of the variables we may put the Hamiltonian in the form

$$(19) \quad c_1x^2 + c_2xy + c_3y^2 + xy^2, \quad c_2^2 - 4c_1c_3 < 0.$$

As $c_1 \neq 0$ then this polynomial is semiweighted homogeneous (in the sense of Section 2), with $2 \text{wdeg}(y) = \text{wdeg}(x)$ and highest weighted homogeneous part equal to $c_1x^2 + xy^2$. Using Theorem 1 we conclude that \mathcal{P}_H is free of rank $\mu = \dim \mathbb{C}[x, y]/\langle H_x, H_y \rangle$. An easy computation shows that the global Milnor number of H is equal to three, and moreover

$$\mathbb{C}[x, y]/\langle H_x, H_y \rangle = \mathbb{C}[x, y]/\langle H_x^0, H_y^0 \rangle = \text{Vect}\{1, x, y\}$$

which implies Proposition 5, (ii).

To compute the module of Abelian integrals \mathcal{A}_δ we note that

$$(20) \quad H_1(H^{-1}(h_0), \mathbb{C}) = V_{\delta(h_0)}$$

which, combined with Theorem 2 implies that the map (18) is an isomorphism. Indeed, if H has distinct critical values ($8a^2 + 4a + b^2 \neq 0$ in this case) then (20) follows from the fact that the Dynkin diagram of any (and hence of H) swh polynomial is connected (see for example the proof of [7], Prop. 3.2). If $8a^2 + 4a + b^2 = 0$ the polynomial H has two Morse critical points and one cusp. The identity (20) follows from an explicit computation of the orbit of $\delta(h_0)$ under the action of the monodromy group. To do this we need the Dynkin diagram of H which will be computed in the next section.

It remains to compute the dimension of the vector space \mathcal{A}_n . In the case when H is a weighted homogeneous ($b^2 - 4a^3 \neq 0$) polynomial we have

$$I(h) \in \mathcal{A}_n \iff I(h) = pX + qY + rK + sM$$

where p, q, r, s are real polynomials in h of degree $[\frac{1}{3}(n - 2)]$, $[\frac{1}{3}(n - 2)]$, $[\frac{1}{3}(n - 3)]$, $[\frac{1}{3}(n - 1)]$ respectively. It follows that

$$\begin{aligned} \dim \mathcal{A}_n &= [\tfrac{1}{3}(n - 2)] + [\tfrac{1}{3}(n - 2)] + [\tfrac{1}{3}(n - 3)] + [\tfrac{1}{3}(n - 1)] + 4 \\ &= [\tfrac{1}{3}(4n + 1)]. \end{aligned}$$

The above does not work if $b^2 - 4a^3 = 0$ but we may compute $\dim \mathcal{A}_n$ in the following way. As \mathcal{A}_δ is isomorphic to \mathcal{P}_H then \mathcal{A}_n is isomorphic (as a vector space) to the space of degree n polynomial one-forms $P_n dx + Q_n dy$, modulo polynomial one-forms $dA + B dH$. Using the isomorphism of the vector spaces

$$\mathcal{P}_H \longrightarrow \Omega^2/d\Omega^0 \wedge dH : \omega \longmapsto d\omega$$

we conclude that \mathcal{A}_n is isomorphic to the vector space of two-forms

$$R_{n-1}(x, y) dx \wedge dy, \quad \deg R_{n-1} \leq n - 1$$

modulo two-forms

$$dA \wedge dH, \quad \deg A(x, y) \leq n - 2$$

(see Section 2). Indeed, if $g(x, y)$ is a homogeneous polynomial, then

$$dg \wedge d(xy^2) = 0 \iff g(x, y) = (xy^2)^k.$$

Using this and (19) we conclude that if $R_{n-1}(x, y) dx \wedge dy = dA \wedge dH$ where $\deg R_{n-1} \leq n - 1$, then there always exists a polynomial A_{n-2} of degree less or equal to $n - 2$, such that $R_{n-1}(x, y) dx \wedge dy = dA_{n-2} \wedge dH$. Similarly

$$dA \wedge dH \equiv 0, \quad A \in \mathbb{R}[x, y] \iff \exists f \in \mathbb{R}[h], \quad A(x, y) = f(H(x, y)).$$

Finally we have

$$\begin{aligned} \dim \mathcal{A}_n &= \dim\{R_{n-1} \in \mathbb{R}[x, y]; \deg R_{n-1} \leq n - 1\} \\ &\quad - \dim\{A_{n-2} \in \mathbb{R}[x, y]; \deg A_{n-2} \leq n - 2\} \\ &\quad + \dim\{f \in \mathbb{R}[h]; \deg f(H(x, y)) \leq n - 2\} \\ &= \tfrac{1}{2}n(n + 1) - \tfrac{1}{2}(n - 1)n + [\tfrac{1}{3}(n - 2)] + 1 \\ &= [\tfrac{1}{3}(4n + 1)]. \end{aligned}$$

This completes the proof of Proposition 5. □

6.2. Reversible quadratic Hamiltonian vector fields with a center.

In this section we suppose that the real polynomial $H(x, y)$ defined by (17) is reversible (equivalently $b((1+2a)(1-a)^2 - b^2) = 0$). As a matter of fact it suffices to study the Hamiltonians (24) below, that is to say $b = 0$. Indeed, any reversible vector field $X_0 \in Q_3^R$ can be written in the form [30]

$$(21) \quad \dot{x} = y(1 + dx), \quad \dot{y} = -x - ay^2 + cx^2.$$

It has an axis of symmetry $\{y = 0\}$ and an invariant line $\{1 + dx = 0\}$. If we suppose in addition that (21) is Hamiltonian then we have $d = 2a$ and

$$(22) \quad H(x, y) = \frac{1}{2}(x^2 + y^2) - \frac{c}{3}x^3 + axy^2.$$

The cubic Hamiltonian $H(x, y)$, $a \neq 0$, has a reducible level set

$$(23) \quad H(x, y) - \frac{3a + c}{24a^3} = \left(x + \frac{1}{2a}\right) \left(ay^2 - \frac{c}{3}x^2 + \frac{3a + c}{6a}x - \frac{3a + c}{12a^2}\right)$$

and vice versa: any real cubic polynomial with an elliptic critical point and at least one reducible level set is equivalent, under a real linear change of the variables, to the Hamiltonian (22). A real homothetic transformation of x, y shows that the family (22) is naturally parameterized by the projective line $\mathbb{P}\mathbb{R}^1 \ni [a:c]$. If we put $c = 1$, then we obtain the following normal form of cubic reversible Hamiltonians with a center:

$$(24) \quad \begin{cases} H(x, y) = \frac{1}{2}(x^2 + y^2) - \frac{1}{3}x^3 + axy^2, & a \neq \infty \\ H(x, y) = \frac{1}{2}(x^2 + y^2) + xy^2, & a = \infty. \end{cases}$$

• For $a \neq 0, \infty$ the critical points of $H(x, y)$ (24) are $(x_1, y_1) = (0, 0)$, $(x_2, y_2) = (1, 0)$, and

$$(x_3, y_3) = \left(-\frac{1}{2a}, +\frac{1}{2a}\sqrt{\frac{1+2a}{a}}\right), \quad (x_4, y_4) = \left(-\frac{1}{2a}, -\frac{1}{2a}\sqrt{\frac{1+2a}{a}}\right)$$

with corresponding critical values

$$h_1 = 0, \quad h_2 = \frac{1}{6}, \quad h_3 = h_4 = \frac{3a + 1}{24a^3}.$$

• For $a = 0$ we have only two critical points $(x_1, y_1) = (0, 0)$, $(x_2, y_2) = (1, 0)$, with corresponding critical values $h_1 = 0$ and $h_2 = \frac{1}{6}$.

- For $a = \infty$ the Hamiltonian function (24) has three critical points

$$(x_1, y_1) = (0, 0), \quad (x_3, y_3) = \left(-\frac{1}{2}, \frac{1}{\sqrt{2}}\right), \quad (x_4, y_4) = \left(-\frac{1}{2}, -\frac{1}{\sqrt{2}}\right)$$

with corresponding critical values $h_1 = 0, h_3 = h_4 = \frac{1}{8}$.

In the case when the critical point (x_i, y_i) is a saddle (center) of the vector field (16), we shall denote $(x_i, y_i) = (x_i^s, y_i^s) ((x_i^c, y_i^c))$. Similar notations will be used for the critical values h_i .

The topology of the real fibration

$$\mathbb{R}^2 \xrightarrow{H} \mathbb{R}$$

is one and the same when a belongs to one of the open intervals $]-\infty, -\frac{1}{2}[$, $]-\frac{1}{2}, 0[$, $]0, 1[$, or $]1, \infty[$. Selected level curves of H are shown on Fig. 2.

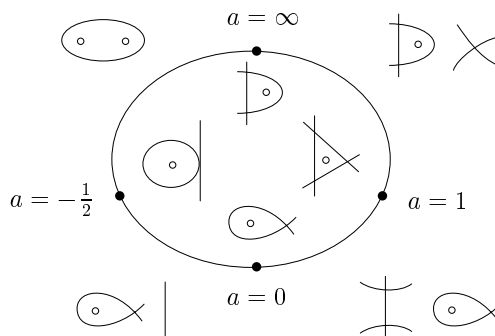

Figure 2. Selected level curves of the polynomial (24)
 $H(x, y) = \frac{1}{2}(x^2 + y^2) - \frac{1}{3}x^3 + axy^2$.

We are going to study now the topology of the global Milnor fibration

$$\mathbb{C}^2 \xrightarrow{H} \mathbb{C}.$$

Note that the Hamiltonians (24) are semiweighted homogeneous so the results of [6], Section 2, apply. In particular we have that for regular values $h \in \mathbb{C}$ the complex affine curve $H^{-1}(h) \subset \mathbb{C}^2$ is an elliptic curve with

- one removed point ($a = 0$),
- two removed points ($a = \infty$),
- three removed points ($a \neq 0, \infty$).

Suppose that $h_{3,4} \neq h_1, h_2$, that is to say $a \neq -\frac{1}{2}, -\frac{1}{3}, 0, 1$. Let $h = h_0$ be a fixed regular value with $\text{Im}(h_0) > 0$ and let $\ell_1, \ell_2, \ell_{3,4}$ be three mutually non-intersecting paths, connecting h_0 to h_i , and contained in the upper half-plane $\text{Im}(h) > 0$ (except their ends which coincide with h_i). Denote by $\delta_i(h) \in H_1(H^{-1}(h), \mathbb{Z})$ the continuous families of cycles which vanish at (x_i, y_i) as h tends to h_i along the path ℓ_i . For all regular h the cycles $\delta_i(h)$ form a basis of the first integer homology group of the affine algebraic curve $H^{-1}(h) \subset \mathbb{C}^2$. The families $\delta_i(h)$ define locally constant sections of the global homology Milnor bundle of $H(x, y)$ with base $\mathbb{C} \setminus \{h_1, h_2, h_{3,4}\}$ and fibre $H_1(H^{-1}(h), \mathbb{Z})$. Note that although $h_3 = h_4$, the sections δ_3, δ_4 are well defined, due to the fact that $\delta_3(h)$ and $\delta_4(h)$ vanish in the same level set of H , and hence their intersection index is equal to zero.

DEFINITION 6. — *The Dynkin diagram of $H(x, y)$ is the graph with vertices the cycles δ_i . Two cycles $\delta_i, \delta_j, h_i < h_j$, are connected by an edge (dotted edge) if the intersection index $\delta_i \circ \delta_j$ is equal to $+1$ (-1).*

The Dynkin diagram of H describes the intersection indices $\delta_i \circ \delta_j$, and hence the monodromy group \mathbf{M} . It depends, however, on the homotopy class of the non-intersecting paths ℓ_i .

PROPOSITION 6. — *The Dynkin diagram of the polynomial H (24) is shown on Fig. 3.*

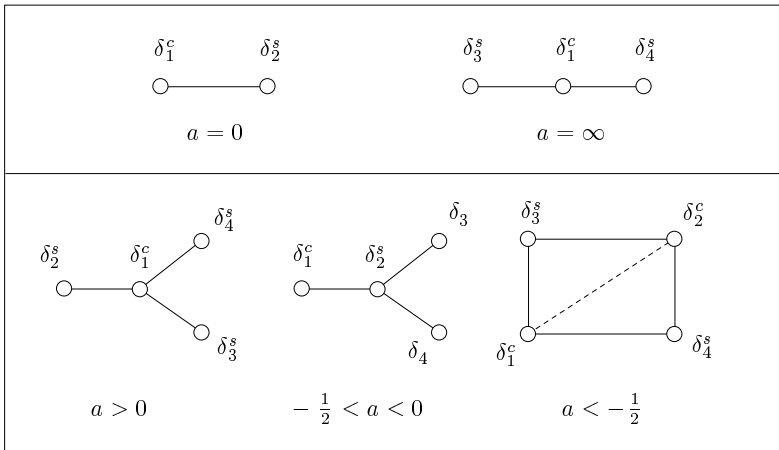

Figure 3. Dynkin diagram of the polynomial (24).

Proof. — The critical values of H are easily computed (Table 1).

$a < -\frac{1}{2}$	$h_1^c < h_{3,4}^s < h_2^c$
$a = -\frac{1}{2}$	$h_1^c < h_{3,4} = h_2$
$-\frac{1}{2} < a < -\frac{1}{3}$	$h_1^c < h_{3,4} < h_2^s$
$a = -\frac{1}{3}$	$h_1^c = h_{3,4} < h_2^s$
$-\frac{1}{3} < a < 0$	$h_{3,4} < h_1^c < h_2^s$
$a = 0$	$h_1^c < h_2^s$
$0 < a < 1$	$h_1^c < h_2^s < h_{3,4}^s$
$a > 1$	$h_1^c < h_{3,4}^s < h_2^s$
$a = \infty$	$h_1^c < h_{3,4}^s$

Table 1. The critical values, for $a \in \mathbb{RP}^1$, of $H(x, y) = \frac{1}{2}(x^2 + y^2) - \frac{1}{3}x^3 + axy^2$.

In the Hamiltonian triangle case $a = 1$ the polynomial H has only real Morse critical points, and all saddle points are contained in the same level set $\{H = \frac{1}{6}\}$. The Dynkin diagram in this case (as well for a close to 1) follows from the results of A’Campo and Husein-Zade [1], [14], [2]. For $a \in]0, 1[$ or $a \in]1, \infty[$ the polynomial H defines topologically equivalent global Milnor fibrations (see for example [6], Thm 2.5) and hence its Dynkin diagram is one and the same.

If $a < -\frac{1}{2}$ the polynomial H has only real Morse critical points, and all the saddle points are contained in the level set $\{H = (3a + 1)/24a^3\}$. As before we may use the method of A’Campo and Husein-Zade. In the same way we obtain the Dynkin diagram of the parabolic case $a = \infty$ and the case $a = 0$.

Note finally that

$$\tilde{H}(x, y) = H\left(1 - x, \sqrt{-1} \frac{y}{\sqrt{1 + 2a}}\right) = \frac{1}{6} - \left[\frac{1}{2}(x^2 + y^2) - \frac{1}{3}x^3 + \tilde{a}xy^2\right]$$

where $\tilde{a} = -a/(1 + 2a)$ is a real polynomial. If $a \in]-\frac{1}{2}, 0[$ then $\tilde{a} > 0$ and hence the Dynkin diagram of H is obtained from the Dynkin diagram of \tilde{H} (after exchanging δ_1^c and δ_2^s). \square

Denote the compactified and normalized fibre $H^{-1}(h) \subset \mathbb{C}^2$ by Γ_h . For every h the affine elliptic curve $H^{-1}(h) \subset \mathbb{C}^2$ has an elliptic involution

$$i : (x, y) \longmapsto (x, -y).$$

This defines an elliptic involution on Γ_h which permutes its “infinite” points. We have

- $\Gamma_h = H^{-1}(h) \cup P_0 \cup P_+ \cup P_-$, $a \neq 0, \infty$;
- $\Gamma_h = H^{-1}(h) \cup P_+ \cup P_-$, $a = \infty$;
- $\Gamma_h = H^{-1}(h) \cup P_0$, $a = 0$

and without loss of generality,

$$i(P_0) = P_0, \quad i(P_{\pm}) = P_{\mp}.$$

If z is a uniformizing parameter on the elliptic curve Γ_h , such that $z = 0$ is a fixed point of i , then $i(z) = -z$. It follows that i acts on $H_1(\Gamma_h, \mathbb{Z})$ as $-\text{id}$.

PROPOSITION 7. — *The Petrov $\mathbb{R}[h]$ module \mathcal{P}_H associated to the Hamiltonian (24), is freely generated by the one-forms*

- $\omega_X, \omega_Y, \omega_M, \omega_L$, $a \neq 0, \infty$;
- $\omega_X, \omega_Y, \omega_M$, $a = \infty$;
- ω_X, ω_M , $a = 0$.

The proof follows from Theorem 1. Indeed, for $a \neq 0, \infty$ the vector space $\mathbb{C}[x, y]/\langle H_x, H_y \rangle$ is generated by $1, x, y, x^2$, for $a = \infty$ by $1, x, y$, and for $a = 0$ by $1, x$. \square

Denote by $\delta(h) \subset H^{-1}(h)$ the real oval of H surrounding the origin in \mathbb{R}^2 , and defined for small positive h and consider the associated $\mathbb{R}[h]$ module \mathcal{A} (9) of Abelian integrals.

PROPOSITION 8. — *The $\mathbb{R}[h]$ module \mathcal{A}_δ associated to the Hamiltonian (24) is freely generated by the Abelian integrals*

- $X(h), L(h), M(h)$ in the case $a \neq 0, 1, \infty$;
- $L(h), M(h)$ in the case $a = 1$;
- $X(h), M(h)$ in the case $a = 0, \infty$.

Proof. — We have $i^*\omega_Y = \omega_Y$, $i_*\delta = -\delta$, and hence $Y(h) \equiv 0$. On the other hand using the Dynkin diagram Fig. 3, Table 1, and the Picard-Lefschetz formula we get

- if $a > 0$, $a \neq 1$, then

$$E_{\delta_1^c(t_0)} = \text{Span}\{\delta_1^c(t_0), \delta_2^s(t_0), \delta_3^s(t_0) + \delta_4^s(t_0)\}, \quad \text{rank } E_{\delta_1^c} = 3;$$

- if $a < 0$, then

$$E_{\delta_1^c(t_0)} = \text{Span}\{\delta_1^c(t_0), \delta_2^s(t_0), \delta_3(t_0) + \delta_4(t_0)\}, \quad \text{rank } E_{\delta_1^c} = 3;$$

- if $a = 1$, then

$$E_{\delta_1^c(t_0)} = \text{Span}\{\delta_1^c(t_0), \delta_2^s(t_0) + \delta_3^s(t_0) + \delta_4^s(t_0)\}, \quad \text{rank } E_{\delta_1^c} = 2;$$

- if $a = 0$, then

$$E_{\delta_1^c(t_0)} = \text{Span}\{\delta_1^c(t_0), \delta_2^s(t_0)\}, \quad \text{rank } E_{\delta_1^c} = 2;$$

- if $a = \infty$, then

$$E_{\delta_1^c(t_0)} = \text{Span}\{\delta_1^c(t_0), \delta_3^s(t_0) + \delta_4^s(t_0)\}, \quad \text{rank } E_{\delta_1^c} = 2.$$

If $a \neq -\frac{1}{2}$ Proposition 8 follows from Theorem 2. In the case $a = -\frac{1}{2}$ the decomposition (12) still holds true which implies Lemma 1 and hence Theorem 2. Thus Proposition 8 holds also in the case when the cubic polynomial H is not of Morse type. □

Consider the real vector subspace $\mathcal{A}_n \subset \mathcal{A}_\delta$ of Abelian integrals

$$\int_\delta P(x, y) dx + Q(x, y) dy, \quad P, Q \in \mathbb{R}[x, y], \quad \deg(P), \deg(Q) \leq n.$$

PROPOSITION 9. — *The dimension of the real vector space \mathcal{A}_n is n if $a \neq 1$, and $\lfloor \frac{1}{3}(2n + 1) \rfloor$ in the Hamiltonian triangle case, $a = 1$.*

Proof. — Suppose first that $a \neq 0, 1, \infty$. In this case the polynomial (24) is semi-homogeneous. An Abelian integral $I(h)$ belongs to the space \mathcal{A}_n if and only if

$$I(h) \equiv p(h)X(h) + q(h)L(h) + r(h)M(h)$$

where p, q, r are real polynomials of degree at most $\lfloor \frac{1}{3}(n - 2) \rfloor, \lfloor \frac{1}{3}(n - 3) \rfloor,$

and $[\frac{1}{3}(n - 1)]$ respectively. As the module \mathcal{A}_δ is free then

$$\dim \mathcal{A}_n = [\frac{1}{3}(n - 2)] + [\frac{1}{3}(n - 3)] + [\frac{1}{3}(n - 1)] + 3 = n.$$

In a similar way in the case case $a = 1$ we have

$$I(h) \equiv q(h)L(h) + r(h)M(h)$$

where q, r are real polynomials of degree at most $[\frac{1}{3}(n - 3)]$ and $[\frac{1}{3}[(n - 1)]]$ respectively, so

$$\dim \mathcal{A}_n = [\frac{1}{3}(n - 3)] + [\frac{1}{3}(n - 1)] + 2 = [\frac{1}{3}(2n + 1)].$$

The case $a = 0$ follows from [23].

Suppose at last that $a = \infty$. We shall modify the proof of Proposition 5 in the case $b^2 - 4a^3 = 0$. Note first that if a polynomial differential one-form ω is even in y , $i^*\omega = \omega$, $i(x, y) = (x, -y)$, then the corresponding Abelian integral $\int_{\delta_1^c(h)} \omega$ is identically zero. So it is enough to consider only integrals of the form

$$\int_{\delta_1^c(h)} \omega, \quad i^*\omega = \omega.$$

If such an integral is identically zero, then we have also

$$\int_{\delta_1^c(h)} \omega \equiv \int_{\delta_3^s(h) + \delta_4^s(h)} \omega \equiv 0.$$

On the other hand $\Gamma_h = H^{-1} \cup P_+ \cup P_-$ where i permutes P_+ and P_- . It follows that ω has no residues, so

$$\int_{\delta_3^s(h) - \delta_4^s(h)} \omega \equiv 0.$$

Thus the restriction of ω on the fibre $H^{-1}(h)$ represents the zero cohomology class in $H^1(H^{-1}(h), \mathbb{C})$, and its “relative cohomology class” $[\omega] \in \mathcal{P}_H$ is zero too [7], Thm 1.2. As in the proof of Proposition 5 we conclude that the vector space \mathcal{A}_n is isomorphic to the vector space of two-forms

$$\omega = R_{n-1}(x, y) dx \wedge dy, \quad \deg R_{n-1} \leq n - 1, \quad i^*\omega = \omega$$

modulo two-forms $dA \wedge dH$, where the real polynomial $A(x, y)$ is even in y , and $\deg A \leq n - 2$. Thus we get

$$\begin{aligned} \dim \mathcal{A}_n &= \dim \{R_{n-1} \in \mathbb{R}[x, y] : \deg R_{n-1} \leq n - 1, \\ &\quad R_{n-1}(x, -y) = R_{n-1}(x, y)\} \\ &\quad - \dim \{A_{n-2} \in \mathbb{R}[x, y] : \deg A_{n-2} \leq n - 2, \\ &\quad A_{n-2}(x, -y) = -A_{n-2}(x, y)\} \\ &= n + (n - 2) + (n - 4) + \dots - (n - 2) - (n - 4) - \dots \\ &= n. \end{aligned} \quad \square$$

7. Polynomial deformations of a quadratic Hamiltonian vector field and non-oscillation of Abelian integrals.

Let

$$X_H = H_y \frac{\partial}{\partial x} - H_x \frac{\partial}{\partial y}$$

be a reversible quadratic polynomial Hamiltonian vector field with one center and one saddle point. It follows from the preceding section that by a linear change of the variables x, y and t we can assume that

$$H(x, y) = \frac{1}{2}(x^2 + y^2) - \frac{1}{3}x^3 + axy^2, \quad \text{where } -\frac{1}{2} < a \leq 0.$$

Consider a polynomial deformation of X_H of the form

$$X_\varepsilon = X_H + \varepsilon Y + o(\varepsilon)$$

where

$$Y = P(x, y) \frac{\partial}{\partial x} + Q(x, y) \frac{\partial}{\partial y}$$

is a polynomial vector field of degree n , $\deg P \leq n$, $\deg Q \leq n$. The first approximation of the return map associated to X_ε is given by the Abelian integral

$$I_Y(h) = \iint_{\{H \leq h\}} \operatorname{div}(Y) \, dx \wedge dy, \quad \operatorname{div}(Y) = P_x + Q_y$$

where $h \in [0, \frac{1}{6}]$.

THEOREM 3. — *Let X_ε be a polynomial deformation of degree n of the Hamiltonian vector field X_H , and assume that $I_Y(h)$ is not identically zero. Let $K \subset \mathbb{R}^2$ be any compact domain. For all sufficiently small ε the vector field X_ε has at most $n - 1$ limit cycles in K . This bound is exact.*

The difficult part of the proof is the study of the Abelian integral I_Y . If $a = 0$ this is done in a well known paper by Petrov [23], [3]. Based on this and on Roussarie’s theorem [26] Mardešić [19] deduced Theorem 3 in the case $a = 0$. Therefore further we suppose that $-\frac{1}{2} < a < 0$. Theorem 3 will be proved at the end of this section. We shall find first the exact upper bound for the number of the zeros of an Abelian integral $I(h) \in \mathcal{A}_\delta$ (we keep the notations of the preceding sections). Using the method of Petrov, we shall compute this number in the larger complex domain $\mathcal{D} = \mathbb{C} \setminus [h_2^s, \infty[$, in which $I(h)$ is a holomorphic function. The determination of the domain \mathcal{D} is crucial for the proof, and it amounts to compute the Dynkin diagram of the polynomial $H(x, y)$ (Proposition 12). The second new observation is that the imaginary part of the holomorphic function $F(h) = I'(h)/M'(h)$ on $[h_2^s, \infty[$ is an expression involving the “relative” complete Abelian integral of first kind

$$\int_{P_-}^{P_+} \omega'_M$$

(see (27), (25)). This can be used to obtain a more transparent proof of results in [10], [24].

Recall that, according to the classical terminology a meromorphic differential one-form on the Riemann surface Γ_h is said to be of first kind if it is holomorphic, of second kind if it has no residues, and it is of third kind if it has only simple poles. Introduce the following notation:

$$Z(h) = (3a - 1)X(h) - 4aL(h), \quad \omega_Z = (3a - 1)\omega_X - 4a\omega_L,$$

$$\omega'_X = \nabla\omega_X = -\frac{x \, dx}{H_y}, \quad \omega'_L = \nabla\omega_L = -\frac{x^2 \, dx}{H_y}, \quad \omega'_M = \nabla\omega_M = -\frac{dx}{H_y}$$

where the one-forms $\omega_X, \omega_M, \omega_L$, and the Abelian integrals $X(h), M(h), L(h)$ were defined in Section 6.

PROPOSITION 10. — *Let $a \neq 0, \infty$. The one-form ω'_M is of first kind, ω'_Z is of second kind, and ω'_X is of third kind. The only residues of ω'_X are at P_\pm .*

Proof. — It is easily checked that ω'_M is holomorphic, ω'_X has only simple poles, and ω'_Z has at most double poles. As $i^*\omega'_X = -\omega'_X$ and $i(P_0) = P(0)$, then $Res_{P_0}\omega'_X = 0$. The fact that ω'_Z has no residues follows from [12], Remark 3.4.

Proposition 10 suggests to replace the Abelian integral $I(h)$ by its derivative. As the Abelian integral $I(h) \in \mathcal{A}_\delta$ always vanishes at $h = 0$ then on any real interval containing $h = 0$ the number of the zeros of $I(h)$ is less or equal to the number of the zeros of $I'(h)$ on the same interval. The next proposition follows from Proposition 8 (and is in fact equivalent to it).

PROPOSITION 11. — For every Abelian integral $I(h) \in \mathcal{A}_n$, $a \neq 0$, holds

$$I'(h) = p(h)X'(h) + q(h)Z'(h) + r(h)M'(h)$$

where p, q, r are suitable unique real polynomials of degree at most $[\frac{1}{3}(n-2)]$, $[\frac{1}{3}(n-3)]$ and $[\frac{1}{3}(n-1)]$ respectively.

Proof. — We use Proposition 8 to express $I(h)$ as a polynomial linear combination in $X(h)$, $Z(h)$, $M(h)$ and then derive with respect to h . It remains to express $X(h)$, $Z(h)$, $M(h)$ as a linear combination in their derivatives. This is a general fact, but in our particular case we can be completely explicit. It follows from [12], Remark 3.4, that

$$\begin{aligned} -X' + (a + 1)L' - 6ahM' + 4aM &= 0, \\ (-12a^2h + a + 1)X' + (2a^2 - a - 1)L' + 12a^2X + a(1 - a)M &= 0, \\ (6h - 1)X' + (12ah - 2a)L' + (3a - 7)X - 16aL + (a + 1)M &= 0. \end{aligned}$$

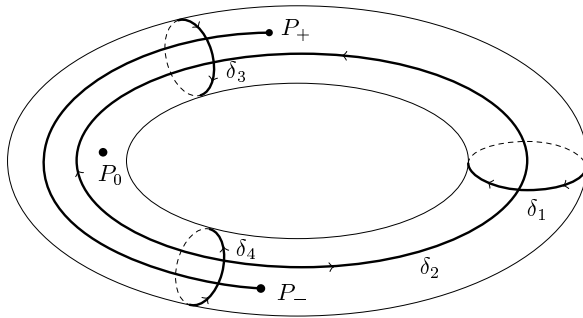

Figure 4. The vanishing cycles on the elliptic curve Γ_h , $-\frac{1}{2} < a < 0$.

Let $\delta_i, i = 1, 2, 3, 4$ be a basis of vanishing cycles of $H_1(H^{-1}(h), \mathbb{Z})$ as on Fig. 4. We have

$$i(\delta_1^c) = -\delta_1^c, \quad i(\delta_2^s) = -\delta_2^s, \quad i(\delta_3^s) = -\delta_4^s, \quad i(\delta_4^s) = -\delta_3^s.$$

Consider the vector space \mathcal{A}_n of Abelian integrals

$$\int_{\delta_1^c} P(x, y) dx + Q(x, y) dy, \quad P, Q \in \mathbb{R}[x, y], \quad \deg(P), \deg(Q) \leq n$$

and the vector space $\mathcal{A}'_n = \{I'(h): I(h) \in \mathcal{A}_n\}$. The following observation is crucial in the proof of the non-oscillation property

PROPOSITION 12. — *Every Abelian integral $I(h) \in \mathcal{A}_n$ is analytically continued to a holomorphic function in the complex domain $\mathcal{D} = \mathbb{C} \setminus [h_2^s, \infty[$.*

Indeed, according to the Dynkin diagram of H , the intersection index of the cycles δ_1^c and δ_3, δ_4 is zero. The Picard-Lefschetz formula implies that $I(h)$ is a holomorphic function in the complex domain $\mathcal{D} = \mathbb{C} \setminus [h_2^s, \infty[$.

THEOREM 4. — *The space \mathcal{A}'_n is Chebishev in the complex domain \mathcal{D} .*

Remark 5. — In the particular case $a = -\frac{1}{3}$ the polynomial (24) can be put, after a suitable translation, rotation of the axes, and rescaling, in the form

$$H(x, y) = xy + x^3 + y^3.$$

In this case Theorem 4 is usually attributed to Petrov (see [3], p. 111, [17]) who announced it without proof [23], Thm 5. Apparently Petrov believed that the module of Abelian integrals along the ovals of H has only two generators, while in fact it has three. This was noted by Rousseau and Żoładek [27], p. 41, and Żoładek [29], p. 169, who claimed (also without proof) that the Petrov’s result “turns to be not true”. A rigorous proof of Petrov’s theorem, based on [8], is first given in [9].

The dimension of \mathcal{A}'_n is equal to $\dim \mathcal{A}_n = n$. To find a bound for the number of the zeros of $I'(h) \in \mathcal{A}'_n$ in \mathcal{D} we shall evaluate the increment of the argument of $F(h) = I'(h)/M'(h)$ along the boundary of \mathcal{D} . We recall that ω'_M is a holomorphic form and hence $M'(h)$ does not vanish [11]. Denote by $F^+(h)$ (resp. $F^-(h)$) the analytic continuation of

$F(h)$ on $[h_2^s, \infty[$, along a path contained in the half-plane $\text{Im}(h) > 0$ (resp. $\text{Im}(h) < 0$). The Picard-Lefschetz formula implies

$$(25) \quad \text{Im } F^\pm(h) = \pm \frac{\int_{\delta_1^c(h)} \omega' \int_{\delta_2^s(h)} \omega'_M - \int_{\delta_1^c(h)} \omega'_M \int_{\delta_2^s(h)} \omega'}{|M'(h)|^2}.$$

Denote the numerator of the above expression by $W_{\delta_1, \delta_2}(\omega', \omega'_M)$. By Proposition 11 we have

$$W_{\delta_1, \delta_2}(\omega', \omega'_M) = p(h)W_{\delta_1, \delta_2}(\omega'_X, \omega'_M) + q(h)W_{\delta_1, \delta_2}(\omega'_Z, \omega'_M).$$

As ω'_Z, ω'_M have no residues (Proposition 10) then the function $W_{\delta_1, \delta_2}(\omega'_Z, \omega'_M)$ is single valued in h on the complex plain \mathbb{C} and has no poles. Moreover for $|h| \approx \infty$ the asymptotic estimates

$$|M'(h)| \approx |h|^{-1/3}, \quad |Z'(h)| \lesssim |h|^{+1/3}$$

imply that $W_{\delta_1, \delta_2}(\omega'_Z, \omega'_M)$ is bounded in h . It follows that it is a (non-zero) constant. Further the reciprocity law for meromorphic differentials of first and third kind ω'_M and ω'_X [11] imply

$$(26) \quad \begin{aligned} W_{\delta_1, \delta_2}(\omega'_X, \omega'_M) &= \int_{\delta_1} \omega'_X \int_{\delta_2} \omega'_M - \int_{\delta_1} \omega'_M \int_{\delta_2} \omega'_X \\ &= 2\pi\sqrt{-1} \text{Res}_{P_+} \omega'_X \int_{P_-}^{P_+} \omega'_M \end{aligned}$$

where the path of integration from P_- to P_+ in the integral above is contained in Γ_h cut along the loops $\delta_1(h)$ and $\delta_2(h)$ as it is shown on Fig. 4. Note that $\text{Res}_{P_+} \omega'_X$ is an imaginary constant in h , and $\int_{P_-}^{P_+} \omega'_M$ is imaginary too. We obtain finally that on the interval $[h_2^s, \infty[$ holds

$$(27) \quad W_{\delta_1, \delta_2}(\omega', \omega'_M) = \tilde{p}(h)2\pi\sqrt{-1} \int_{P_-}^{P_+} \omega'_M + \tilde{q}(h)$$

where $\tilde{p}(h), \tilde{q}(h)$ are real polynomials of degree at most $[\frac{1}{3}(n-2)]$ and $[\frac{1}{3}(n-3)]$ respectively. Denote by \mathcal{B}_n the vector space of functions (27), continued analytically to holomorphic functions in the larger domain $\mathbb{C} \setminus]-\infty, h_{3,4}[$. Obviously

$$\dim \mathcal{B}_n = [\frac{1}{3}(n-2)] + [\frac{1}{3}(n-3)] + 2.$$

LEMMA 3. — *The space of functions \mathcal{B}_n is Chebishev in the complex domain $\mathbb{C} \setminus]-\infty, h_{3,4}[$.*

Proof. — For $|h| \approx \infty$ we have that $|\tilde{p}(h) \int_{P_-}^{P_+} \omega'_M + \tilde{q}(h)|$ grows no faster than $|h|^{[(n-3)/3]}$ and its imaginary part on $]-\infty, h_{3,4}[$ equals to

$$\pm \tilde{q}(h) \int_{\delta(h)} \omega'_M, \quad \delta(h) \in H_1(H^{-1}(h), \mathbb{Z}).$$

As the one-form ω'_M is holomorphic on the elliptic curve Γ_h (Prop. 10) then the integral $\int_{\delta(h)} \omega'_M$ can not vanish. The argument principle implies that $P(h) \int_{P_-}^{P_+} \omega'_M + Q(h)$ has at most $\deg(\tilde{p}) + \deg(\tilde{q}) + 1 = \dim \mathcal{B}_n - 1$ zeros in the domain $\mathbb{C} \setminus]-\infty, h_{3,4}[$. □

Proof of Theorem 4. — Let R be a big enough constant and r a small enough constant. Denote by \mathcal{D}' the set obtained by removing the small disc $\{|h - h_2^s| < r\}$ from $\mathcal{D} \cap \{|h| < R\}$. To estimate the number of the zeros of the Abelian integral $I'(h)$ in \mathcal{D}' (and hence in \mathcal{D}) we shall evaluate the increment of the argument of the function $F(h)$ along the boundary of \mathcal{D}' .

Along the circle $\{|h| = R\}$ we have

$$|F(h)| \lesssim |h|^{(n-1)/3}$$

and on the interval $]h_2^s, \infty[$ the imaginary part of $F(h)$ has at most $\dim \mathcal{B}_n - 1$ zeros (Lemma 3). At last if $h \approx h_2^s$ then using the Picard-Lefschetz formula we have either

$$(28) \quad |F(h)| \approx C^{te} \neq 0$$

(which is the generic case), or

$$(29) \quad |F(h)| \approx |h|^k$$

or

$$(30) \quad |F(h)| \approx \frac{|h|^k}{|\log(h)|}.$$

In the first case the change of the argument of $F(h)$, when h makes one turn along the circle $\{|h - h_2^s| = r\}$ is close to zero. This yields that the increment of the argument of $F(h)$ along the boundary of \mathcal{D}' is less than

$$2\pi\left(1 + \frac{1}{3}(n - 1) + \dim \mathcal{B}_n - 1\right) \leq 2\pi(n - 1)$$

and hence $F(h)$ can have at most $n - 1$ zeros in \mathcal{D}' . Finally we note that in the case (29) the argument of $F(h)$ decreases by at least $2\pi k$. This yields an even sharper estimate for the number of the zeros of $F(h)$. The third case (30) is similar: we note that the argument of $1/|\log(h)|$ decreases along the circle $\{|h - h_2^s| = r\}$, and this decrease is close to zero. □

The above reasonings indicate that it is possible to control the zeros which “accumulate” at the point h_2^s on the boundary of \mathcal{D} . This will be used when studying limit cycles in a neighborhood of the separatrix loop of the unperturbed Hamiltonian system (16).

Recall that in a neighborhood of h_2^s holds

$$I'(h) = (\text{holomorphic function}) \log(h - h_2^s) + \text{holomorphic function.}$$

Thus we have either

$$(31) \quad |I'(h)| \approx |(h - h_2^s)^{k/2} \log(h - h_2^s)|, \quad \text{where } k \text{ is even}$$

or

$$(32) \quad |I'(h)| \approx |h - h_2^s|^{(k-1)/2}, \quad \text{where } k \text{ is odd.}$$

It may be shown (Roussarie [26]) then, that any function of the form

$$\tilde{I}'(h) = (\text{holomorphic function}) \log(h - h_2^s) + \text{holomorphic function,}$$

sufficiently close to $I'(h)$, can have at most k zeros in $\{|h - h_2^s| < r\} \cap \mathcal{D}$. This justifies the following

DEFINITION 7. — We shall say that $I'(h) \in \mathcal{A}_n$, $h \in \mathcal{D}$ has a zero of multiplicity k at $h_2^s \in \partial\mathcal{D}$, provided that either the estimate (31), or the estimate (32) holds.

THEOREM 5. — If the Abelian integral $I'(h) \in \mathcal{A}_n$ has a zero of multiplicity k at $h = h_2^s$, then it has at most $n - k - 1$ zeros in \mathcal{D} . This bound is exact.

Proof. — Consider first the case k even, and the estimate (31) holds. Then

$$\left| \int_{\delta_2^s(h)} \omega' \right| \approx |h - h_2^s|^{k/2}$$

and hence

$$|W_{\delta_1^c, \delta_2^s}(\omega', \omega'_M)| \lesssim |h - h_2^s|^{k/2}.$$

Thus $W_{\delta_1, \delta_2}(\omega', \omega'_M)$ has a zero of order at least $\frac{1}{2}k$ at h_2^s , and by Lemma 3 the number of the zeros of the imaginary part of $F(h)$ on the interval $]h_2^s, \infty[$

is less or equal to $\dim \mathcal{B}_n - 1 - \frac{1}{2}k$. On the other hand for $h \approx h_2^s$ holds $|F(h)| \approx |h|^{k/2}$. As in the proof of Theorem 4 we compute now the increment of the argument of $F(h)$ when h makes one turn along the boundary of \mathcal{D}' in a positive direction. Taking into account that when h makes one turn along the small circle $\{|h - h_2^s| = r\}$, the *decrease* of the argument of $F(h)$ is close to πk we conclude that $F(h)$ has at most $n - k - 1$ zeros in \mathcal{D} .

The case k odd and the estimate (32) holds is studied in a similar way. We have

$$\left| \int_{\delta_2^s(h)} \omega' \right| \approx |h - h_2^s|^{(k+1)/2}$$

and hence

$$|W_{\delta_1^s, \delta_2^s}(\omega', \omega'_M)| \lesssim |h - h_2^s|^{(k-1)/2}.$$

It follows that $W_{\delta_1, \delta_2}(\omega', \omega'_M)$ has a zero of order at least $\frac{1}{2}(k - 1)$ at h_2^s , and by Lemma 3 the number of the zeros of the imaginary part of $F(h)$ on the interval $]h_2^s, \infty[$ is less or equal to $\dim \mathcal{B}_n - 1 - \frac{1}{2}(k - 1)$. Along the circle $\{|h - h_2^s| = r\}$ holds

$$|F(h)| \approx \frac{|h|^{(k-1)/2}}{|\log(h)|}.$$

The factor $h^{(k-1)/2}$ corresponds to a decrease of the argument of $F(h)$ close to $\pi(k - 1)$. The factor $1/\log(h)$ corresponds to a decrease of the argument of $F(h)$ close to zero. The point is that when h makes one turn along the circle $\{|h - h_2^s| = r\}$, then the imaginary part of the function $F(h)/h^{(k-1)/2}$ has exactly one zero (at $h = h_2^s - r$). Using the argument principle we conclude that $F(h)$ has at most $n - k - 1$ zeros in \mathcal{D} . □

Proof of Theorem 3. — If ε is sufficiently small the compact domain K contains only two critical points of the vector field X_ε . When $\varepsilon \rightarrow 0$ a limit cycle of X_ε tends either to a periodic solution of X_H , to the origin $(0, 0)$, or to the homoclinic loop $\{H = \frac{1}{6}\}$.

According to the Poincaré-Pontryagin criterion the number of limit cycles of X_ε which tend to a periodic solution of X_H is less or equal to the number of the zeros of the Abelian integral $I_Y(h)$ on the open interval $]0, \frac{1}{6}[$, which on its hand equals the number of the zeros of $I'_Y(h)$ (as $I_Y(0) = 0$). The number of limit cycles which tend to the origin is less or equal to the order of $I_Y(h)$ at $h = 0$ minus one, and hence equals to the order of $I'_Y(h)$

at $h = 0$. Finally, to evaluate the number of the limit cycles which tend to the homoclinic loop $\{H = \frac{1}{6}\}$ we shall use Roussarie's theorem [26]. In our case it can be stated in the following form (see [19]): “*Suppose that k limit cycles tend to a homoclinic loop with a non-degenerate saddle point, as $\varepsilon \rightarrow 0$. Then the Abelian integral $I_Y'(h)$ has a zero of multiplicity at least k at $h = h_2$.*” Theorem 5 implies Theorem 3. \square

BIBLIOGRAPHY

- [1] N. A'CAMPO, Le groupe de monodromie du déploiement des singularités isolées de courbes planes, I, Math. Ann., 213 (1975), 1–32.
- [2] V.I. ARNOLD, S.M. GUSEIN-ZADE, A.N. VARCHENKO, Singularities of Differentiable Maps, vols. 1 and 2, Monographs in mathematics, Birkhäuser, Boston, 1985 and 1988.
- [3] V.I. ARNOLD, Yu. S. IL'YASHENKO, Ordinary Differential Equations, in ‘Dynamical Systems, I’, Encyclopaedia of Math. Sci., vol. 1, Springer, Berlin, 1988.
- [4] V.I. ARNOLD, Geometrical Methods in the Theory of Ordinary Differential Equations, Springer, New York, 1988.
- [5] E. BRIESKORN, Die Monodromie der isolierten Singularitäten von Hyperflächen, Manuscripta Math., 2 (1970), 103–161.
- [6] L. GAVRILOV, Isochronicity of plane polynomial Hamiltonian systems, Nonlinearity, 10 (1997), 433–448.
- [7] L. GAVRILOV, Petrov modules and zeros of Abelian integrals, Bull. Sci. Math., 122 (1998), 571–584.
- [8] L. GAVRILOV, Nonoscillation of elliptic integrals related to cubic polynomials of order three, Bull. London Math. Soc., 30 (1998), 267–273.
- [9] L. GAVRILOV, Modules of Abelian integrals, Proc. of the IVth Catalan days of applied mathematics, p. 35–45, Tarragona, Spain, 1998.
- [10] L. GAVRILOV, E. HOROZOV, Limit cycles of perturbations of quadratic vector fields, J. Math. Pures Appl., 72 (1993), 213–238.
- [11] P.A. GRIFFITHS, J. HARRIS, Principles of Algebraic Geometry, John Wiley and Sons, 1978.
- [12] E. HOROZOV, I. ILIEV, Linear estimate for the number of zeros of Abelian integrals with cubic Hamiltonians, Nonlinearity, 11 (1998), 1521–1537.
- [13] E. HOROZOV, I.D. ILIEV, On the number of limit cycles in perturbations of quadratic Hamiltonian systems, Proc. London Math. Soc., 69 (1994), 198–224.
- [14] S.M. HUSEIN-ZADE, Dynkin digrams of singularities of functions of two variables, Functional Anal. Appl., 8 (1974), 10–13, 295–300.
- [15] I.D. ILIEV, Perturbations of quadratic centers, Bull. Sci. Math., 122 (1998), 107–161.
- [16] I.D. ILIEV, Higher-order Melnikov functions for degenerate cubic Hamiltonians, Adv. Diff. Equations, 1 (1996), 689–708.
- [17] Yu. IL'YASHENKO, Dulac's memoir “On Limit Cycles” and related problems of the local theory of differential equations, Russian Math. Surveys, 40 (1985), 1–49.

- [18] B. MALGRANGE, Intégrales asymptotiques et monodromie, *Ann. scient. Ec. Norm. Sup.*, 7 (1974), 405–430.
- [19] P. MARDEŠIĆ, The number of limit cycles of polynomial deformations of a Hamiltonian vector field, *Ergod. Th. and Dynam. Sys.*, 10 (1990), 523–529.
- [20] P. MARDEŠIĆ, Chebishev systems and the versal unfolding of the cusp of order n , Hermann, collection *Travaux en Cours*, 1998.
- [21] W.D. NEUMANN, Complex algebraic curves via their links at infinity, *Inv. Math.*, 98 (1989), 445–489.
- [22] G.S. PETROV, Number of zeros of complete elliptic integrals, *Funct. Anal. Appl.*, 18 (1984), 73–74.
- [23] G.S. PETROV, Elliptic integrals and their nonoscillation, *Funct. Anal. Appl.*, 20 (1986), 37–40.
- [24] G.S. PETROV, Nonoscillation of elliptic integrals, *Funct. Anal. Appl.*, 24 (1990), 45–50.
- [25] L.S. PONTRYAGIN, On dynamic systems close to Hamiltonian systems, *Zh. Eksp. Teor. Fiz.*, 4 (1934), 234–238, in russian.
- [26] R. ROUSSARIE, On the number of limit cycles which appear by perturbation of separatrix loop of planar vector fields, *Bol. Soc. Bras. Math.*, (2), vol.17 (1986), 67–101.
- [27] C. ROUSSEAU, H. ŻOLADEK, Zeros of complete elliptic integrals for 1: 2 resonance, *J. Diff. Equations*, 94 (1991), 41–54.
- [28] M. SEBASTIANI, Preuve d’une conjecture de Brieskorn, *Manuscripta Math.*, 2 (1970), 301–308.
- [29] H. ŻOLADEK, Abelian integrals in unfolding of codimension 3 singular planar vector fields, in ‘Bifurcations of Planar Vector Fields’, *Lecture Notes in Math.*, vol. 1480, Springer (1991).
- [30] H. ŻOLADEK, Quadratic systems with center and their perturbations, *J. Diff. Equations*, 109 (1994), 223–273.

Manuscrit reçu le 15 juillet 1998,
accepté le 8 octobre 1998.

Lubomir GAVRILOV,
Université Paul Sabatier
Laboratoire Émile Picard, UMR 5580
118, route de Narbonne
31062 Toulouse Cedex (France).
gavrilov@picard.ups-tlse.fr